

**2016**

Alesco International AB

Service/ Support  
Ver. 2.64

# **A800/A1100/A1200/A4000 TECHNICAL MANUAL**

Technical manual for Alesco A800/1100/4000 Only for Alesco approved technicians.

# Content

<b>Content</b> .....	<b>2</b>
<b>Version history</b> .....	<b>4</b>
<b>Safety</b> .....	<b>5</b>
GENERAL.....	5
WARNINGS AND IMPORTANT INFORMATION.....	5
<b>Installation</b> .....	<b>7</b>
<b>Standard</b> .....	<b>7</b>
<b>Safety and marking labels</b> .....	<b>8</b>
SAFETY LABELS.....	8
MARKINGS .....	8
<b>Specifications A800 /A1100 /A1200/A4000</b> .....	<b>9</b>
SPECIFIKATIONS A800.....	9
SPECIFIKATIONS A1100 .....	9
SPECIFIKATIONS A1200 .....	9
SPECIFIKATIONS A4000 .....	9
<b>Updating software</b> .....	<b>10</b>
SOFTWARE .....	10
UPDATING.....	10
<b>Downloading machine history</b> .....	<b>11</b>
PREPARATIONS .....	11
DOWNLOADING.....	11
<b>All models software description</b> .....	<b>12</b>
<b>Control panel</b> .....	<b>14</b>
<b>Connection, start/standby switching off and control button</b> .....	<b>15</b>
<b>Effect, cycle time, temperature settings, menu settings and info</b> .....	<b>16</b>
<b>Electric schedule all models</b> .....	<b>17</b>
<b>Cooling block diagram</b> .....	<b>18</b>
<b>Color indication on UMI11</b> .....	<b>19</b>
<b>Troubleshooting</b> .....	<b>20</b>
ERROR CODES A800 /A1100 /A1200/A4000.....	20
MALFUNCTIONS.....	22
<b>Spare parts</b> .....	<b>24</b>
BASE A800/A1100/A1200.....	24
COOLING UNIT A800.....	25
COOLING UNIT A1100/A1200.....	26
COOLING UNIT A4000 P1.....	27
COOLING UNIT IS4000 P2.....	28
COOLING UNIT IS4000 P3.....	29
ELECTRICAL BOX COOLING UNIT A1100/A1200/A4000 .....	30

HOSE PACKAGE COVER, GUIDE AND CONTACT RAIL A800/A1100/A1200/A4000 .....	31
HOSE PACKAGE SECTION A800/A1100/A1200/A4000 .....	31
TOP SECTION A800 .....	32
TOP SECTION A1100/A1200/A4000 .....	33
TOP A800/A1100/A1200/A4000 .....	34
HANDLES, STICKERS AND MAINS CABLE A800/ A1100/A1200 .....	35
<b>Connections at the circuit boards P30 .....</b>	<b>36</b>
<b>Interface ICB31 .....</b>	<b>41</b>
<b>Interface CCB10 .....</b>	<b>42</b>
<b>Measuring and checking hardware.....</b>	<b>44</b>
CHECKING THE RECTIFIER:.....	44
DIODE TEST: .....	44
IGBT (TRANSISTOR) .....	45
HOW TO CHECK AND MEASURE THE SST12 .....	45
CHECKING THE P AND N CHANNELS AT THE ICB31 .....	46
DISASSEMBLY AND MOUNTING ICB31 .....	46
DISASSEMBLY AND MOUNTING CCB10 .....	47
DISASSEMBLY AND ASSEMBLY THE GFP22 WITH MEMBRANE CIRCUIT BOARD.....	48
FLOW SENSOR A4000/A1100/A1200/A800.....	50
HOSE PACKAGE A4000/ A1100/A1200/A800 .....	50
CAPACITORS BANK TESTING A4000/A1100/A1200/A800 .....	51
TEST OF CURRENT LEVEL.....	52



## Version history

2.61 Added new error code E4601 in chapter Troubleshooting/Error codes.

2.61 Added missing NTC sensor, Alesco part number 100406, for cooling block in chapter Spare parts/ Top section A800/A1100/A1200/A4000.

2.62 New cooling block schedule, page 18 New pictures in spare part chapter for A4000, page 27-29

2.63 Added info regarding A4000 Spare part/ Base page 24

2.64 Added info for the High,low and engine protection Page 38

# Safety

## General











Always read through the safety instructions and follow them carefully before starting work with the Alesco induction heaters. The Alesco induction heaters have stringent safety requirements and are manufactured to a high degree of precision. The information contained in this instruction manual describes recommended working methods but must not be considered to override the user's own judgement or local regulations. By reading and following these safety regulations, the user is ensuring a safe working environment for himself and his colleagues.

## Warnings and important information

The following types of safety symbols are used in Alesco International AB's instruction manuals and on the equipment.



- ⚠ Warning!** Do not stand the induction heater on an uneven or unstable surface. The induction heater could tip over and cause personal injury or serious damage to the equipment.
- ⚠ Warning!** Do not touch any objects that have been in the vicinity of the induction tip without checking that the object has cooled down.
- ⚠ Warning!** Unless the paint has been removed before the work piece is heated, use an extractor fan to remove fumes.
- ⚠ Warning!** Wear no metal objects on your hands such as watches, jewellery etc. There is a risk of these also being heated during operation.
- ⚠ Warning!** Anyone with a pacemaker or other technical medical equipment must never use, or be in close proximity to, an active induction heater.
- ⚠ Important!** Always read through the safety instructions and follow them carefully before starting work with the Alesco – 800/1100/1200/4000.
- ⚠ Important!** It is the responsibility of the owner to ensure that the equipment has been installed in accordance with the instructions in this instruction manual. It is the owner's responsibility to ensure that the induction heater has been inspected in accordance with applicable regulations before it is used.
- ⚠ Important!** If the induction heater is used in environments where the temperature is below freezing, anti-freeze must be used. The recommended anti-freeze is 30% propylene glycol.
- ⚠ Important!** Use only Alesco International AB approved accessories and spare parts.

-  **Important!** The induction heater is designed to have a high degree of recyclability. However, it can contain substances which should not be thrown out with normal garbage. Contact Alesco International AB for information about environmentally sound handling.
-  **Important!** The equipment and its components may not be modified without the prior written permission of the manufacturer. The user of the equipment is liable for all technical failures caused by incorrect use, incorrect maintenance, damage, incorrect repair or modification by a party other than the manufacturer or specified by the manufacturer.
-  **Warning!** Do not fill the reservoir with anything other than water, with anti-freeze if necessary. Incorrect handling can cause personal injury and/or damage to the equipment.
-  **Warning!** All major service and maintenance work must be carried out by Alesco International AB's service personnel. Risk of electric shock.
-  **Warning!** Remove no cover plates or carry out work on the induction heater without disconnecting it from the mains supply. Risk of electric shock.
-  **Warning!** Disconnect the induction heater from the mains supply before carrying out service, cleaning or maintenance. Risk of electric shock.
-  **Warning!** Do not touch the inductor when it is activated because it emits a strong magnetic field and heat. Risk of personal injury.
-  **Warning!** When the induction heater is in use the worksite must be cleared of combustible material to avoid it being ignited.
-  **Warning!** Ensure that there is fire extinguishing equipment at hand. Risk of personal injury.
-  **Warning!** Loose cables and hoses constitute a risk of tripping. Risk of personal injury.

## **Installation**

Alesco – 800 is developed for industrial environment. Equipment Class A

Mains voltage 3 x 400V 32A 50/60Hz + PE

Alesco – 1100 is developed for industrial environment. Equipment Class A

Mains voltage 3 x 400V 32A 50/60Hz + PE

Alesco – 1200 is developed for industrial environment. Equipment Class A

Mains voltage 3 x 400V 32A 50/60Hz + PE

Alesco – 4000 is developed for industrial environment. Equipment Class A

Mains voltage 3 x 400V 32A 50/60Hz + PE

## **Standard**



## Safety and marking labels

### Location of safety labels outside

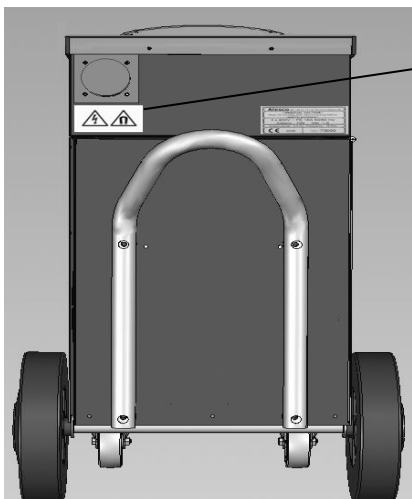

### Inside

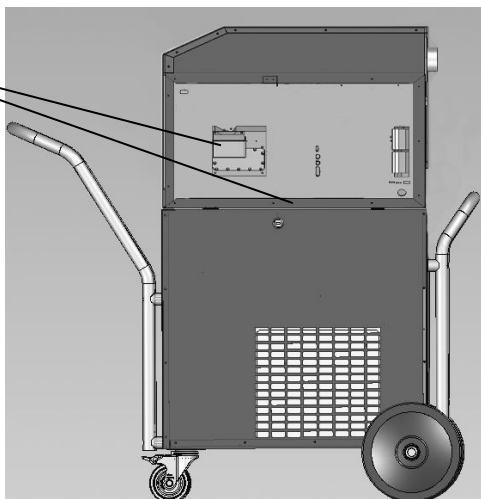

## Safety labels



Electrical installation must only be carried out by an authorised electrician. Disconnect the induction heater from the mains supply before carrying out maintenance or installation work.



Do not use an induction heater at all if you have a pacemaker or other technical medical equipment.

## Markings

The machine's rating plate is located on the back of the Alesco – 800/ 1100/1200/ 4000.

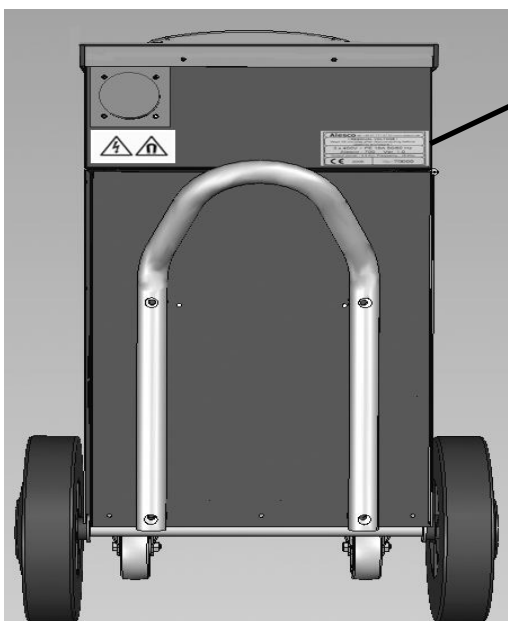



## Specifications A800/A1100/A1200/A4000

### Specifikations A800

Power	8 kW
Weight	54 Kg
Frequency	14-19 kHz
Enclosure	IP21
Water tank	25 Liter
Temperature area	0-40 grader Celsius
Hose package	3 Meter
Dimension	100x50x80 with handle
Mains	3- phase 400V 16A 50/60 Hz + PE

### Specifikations A1100

Power	12 kW
Weight	150 Kg
Frequency	14-19 kHz
Enclosure	IP21
Water tank	25 Liter
Temperature area	0-40 grader Celsius
Hose package	6 Meter
Dimension	80x60x95
Mains	3- phase 400V 16A 50/60 Hz + PE

### Specifikations A1200

Power	12 kW
Weight	150 Kg
Frequency	14-19 kHz
Enclosure	IP21
Water tank	25 Liter
Temperature area	0-40 grader Celsius
Hose package	6 Meter
Dimension	80x60x95
Mains	3- phase 400V 16A 50/60 Hz + PE

### Specifikations A4000

Power	18 kW
Weight	195 Kg
Frequency	14-19 kHz
Enclosure	IP21
Water tank	35 Liter
Temperature area	0-40 grader Celsius
Hose package	6 Meter
Dimension	105x75x110
Mains	3- phase 400V 32A 50/60 Hz + PE

# Updating software

## Software

Alesco International AB reserves the right to update software. When an update of software is called for, install it using a USB stick of not more than 2 Gb. Updates may be provided by Alesco International AB in the form of a programmed USB stick, via e-mail or via Alesco International AB's website. It is then the responsibility of the user to ensure that the memory is formatted and that all other files are removed before the update is installed.

## Updating

It is important to follow this procedure to update successfully:

- Disconnect the machine from the mains supply.
- Open the lock, raise and support the cover using the arm.
- Plug the USB stick into the USB port. Figure 1,2
- Connect the mains cable to the machine. NOTE! The display does not light during update, but the three LEDs next the USB port light as follows. The two closest to the USB port show a green light and the third one shows orange. Figure 3
- When updating is complete, the third LED (orange) goes out. Figure 4
- Remove the USB stick, close the machine and lock the cover.
- Connect the mains cable to the machine and press the start/standby button. The update is now installed and the machine is ready for use.

A4000/ A1100/A1200

A800

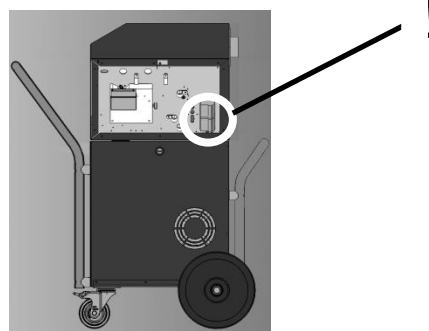
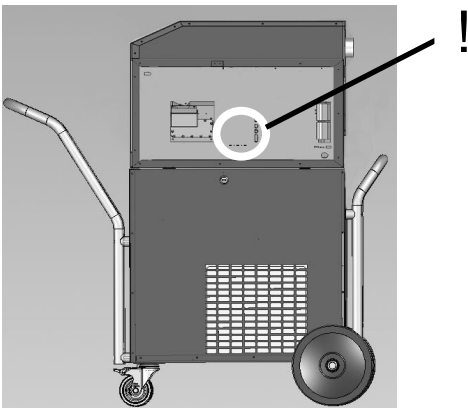

Figure 1

Figure 2

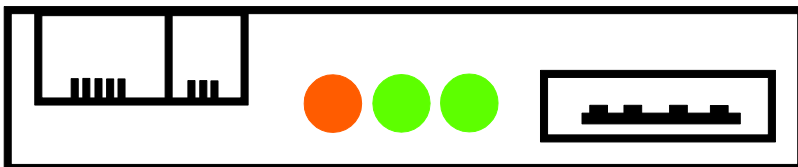

Figure 3

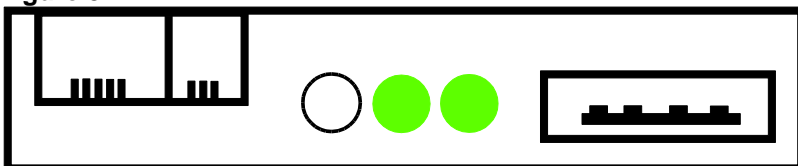

Figure 4

# Downloading machine history

## Preparations

When a history download is necessary prepare a 2 Gb USB-stick by formatting it and copy the “do” txt file to it.

## Downloading

It is important to follow this procedure to download history file successfully:

- Connect the machine to the mains supply.
- Open the lock, raise and support the cover using the arm.
- Wait until the red LEDs starts flashing on the start/standby button at the front panel then plug the USB stick into the USB port. Figure 1, 2
- During the downloading two of the LEDs closest to the UMPA port show an orange light. Figure 3 NOTE! The display at the front panel does not light during downloading, but when downloading is complete, the orange LEDs turn to green. Figure 4
- Remove the USB stick, close the machine and lock the cover.

A4000/ A1100/ A1200

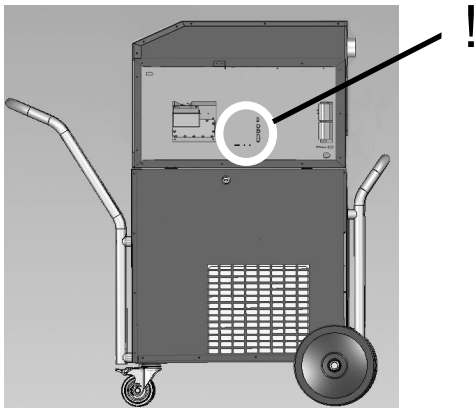

Figure 2

A800

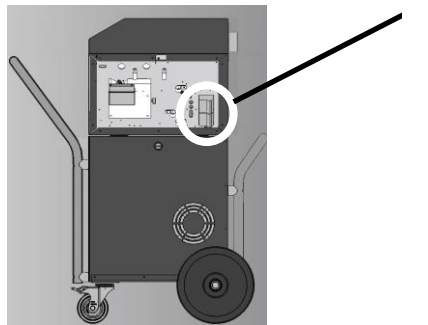

Figure 2

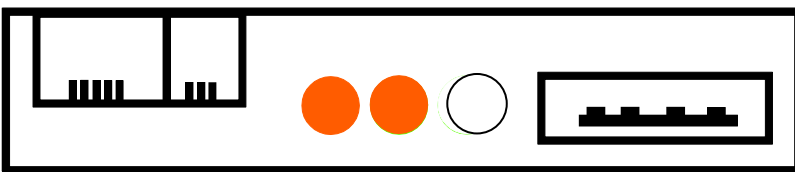

Figure 3

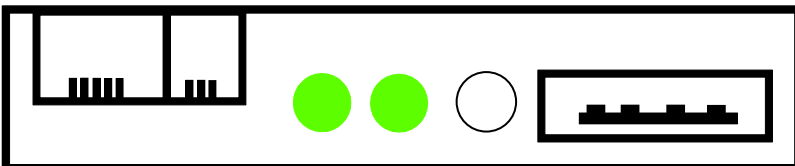
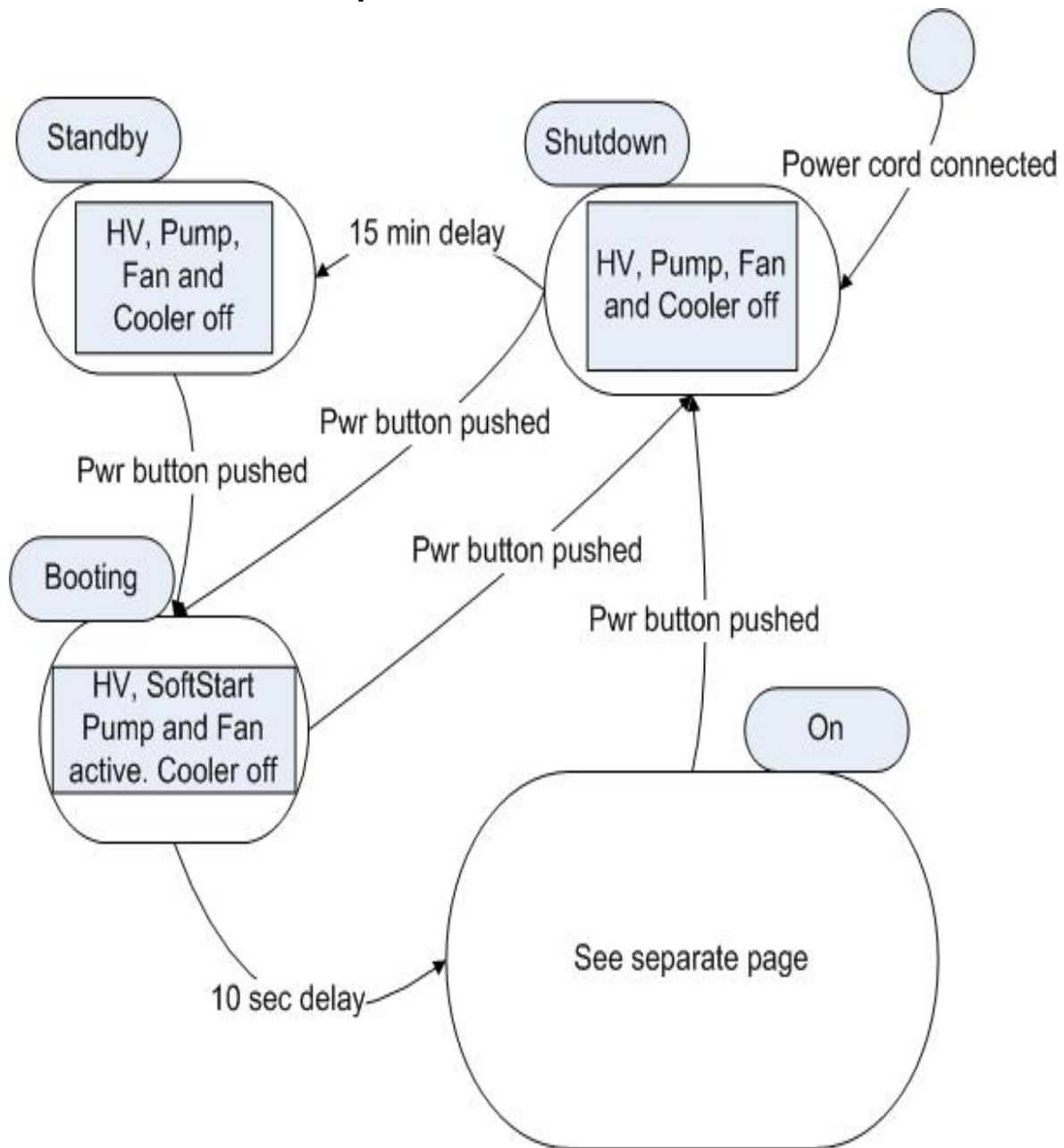
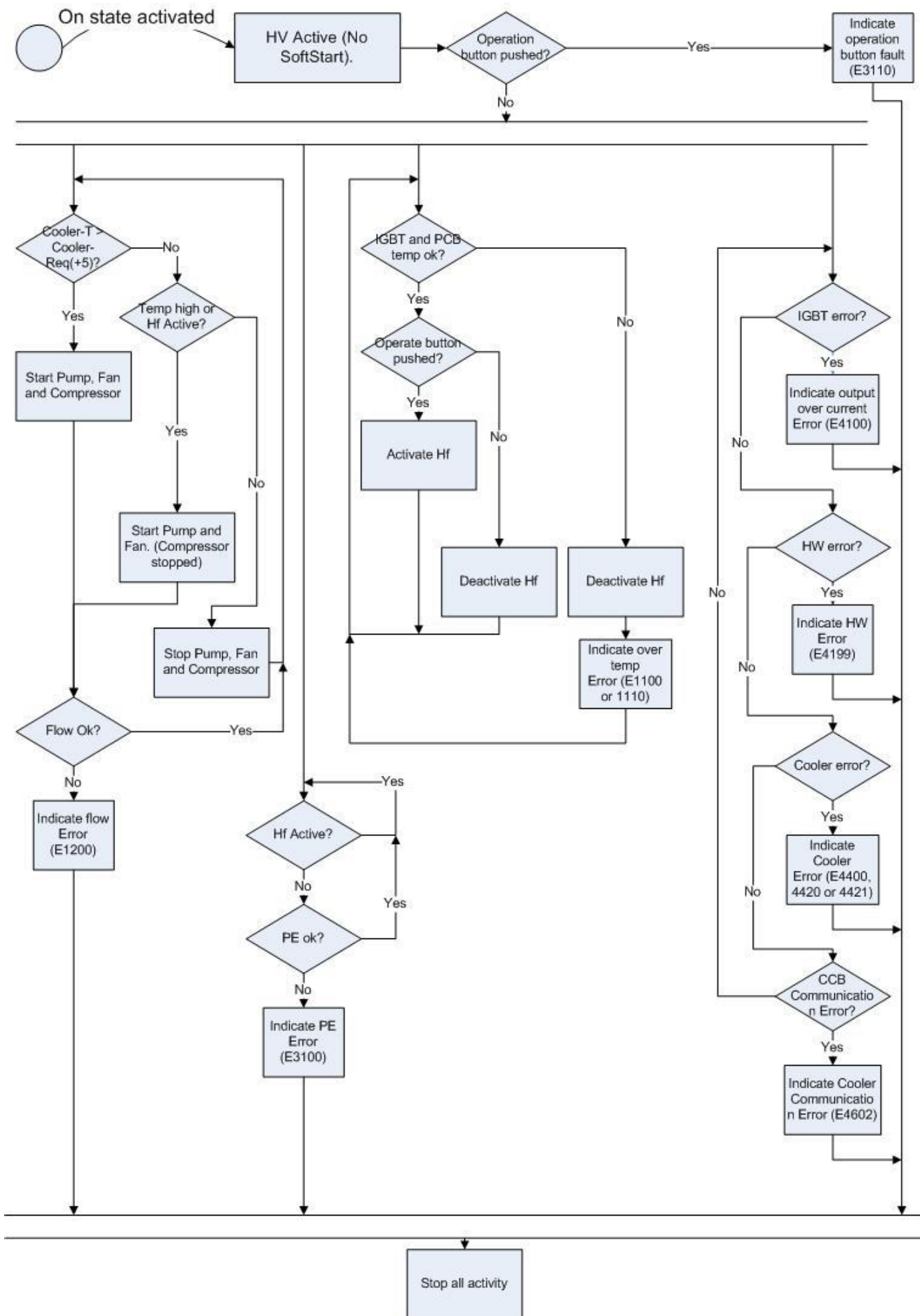

Figure 4

## All models software description





## Control panel

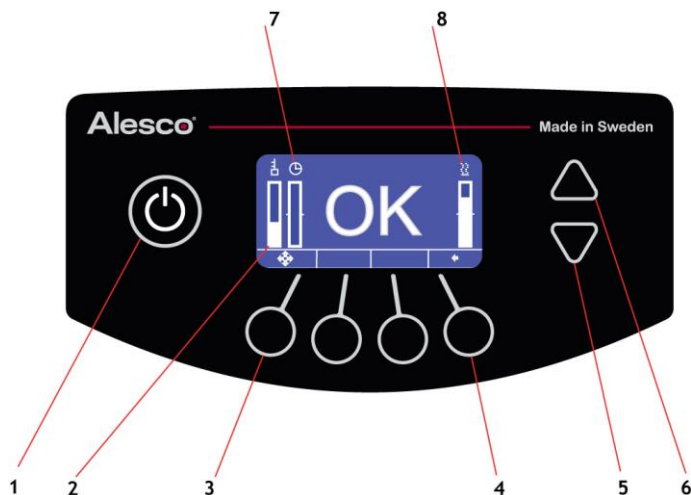

Figure 1

Position	Function
1	Start/Standby
2	Temperature
3	Menu button
4	Return button
5	Arrow down
6	Arrow up
7	*Cycle time
8	Effect

\*Only at A1100/A1200 and A800

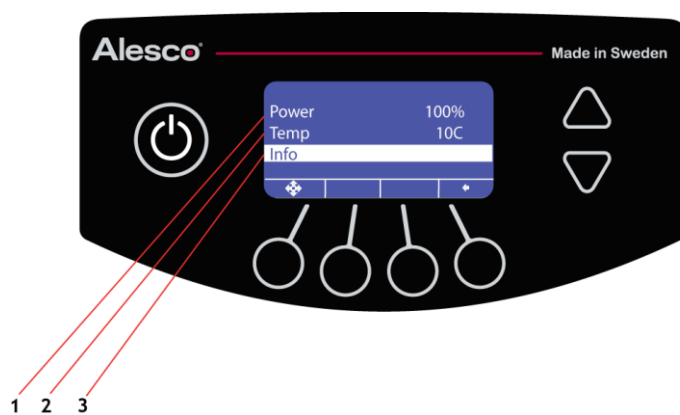
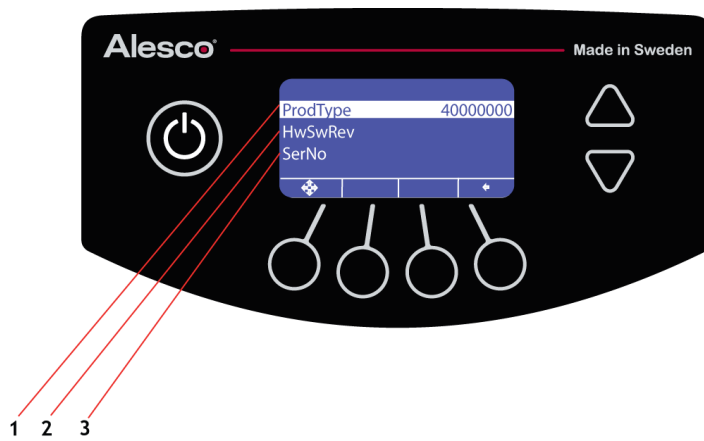

Figure 3

Position	Function
1	Effect setting
2	*Temperature setting
3	Info serial number menu

\*Not included at A800



Position	Function
1	Effect setting
2	*Temperature setting
3	Info serial number menu

## Connection, start/standby switching off and control button

### Connection

Connect the machine wall socket 400V/32A for A4000 or 400V16A for A1100/ A800 with the supplied electrical cable. The start/standby button flashes red to show that the machine is connected but still in standby mode.

### Start/standby

To start the machine, press the start/standby button; it flashes green and a clock shows in the display. When the machine is ready to run, the start/standby button shows a permanent green light and OK shows in the start menu. The machine can now be operated using the control button.

### Switching off

Pressing the start/standby button starts the discharge mode; the display goes out and the button flashes red until the machine is fully discharged via the high voltage cable; complete discharge is indicated by a permanent red light. The high voltage discharge takes 15 minutes. The only way to completely switch off the machine is to disconnect the mains cable and wait 15 minutes.

### Control button

The control button is attached to the transformer with a rotating clip. During heating, the OK indication goes out and instead the display shows an inductor that is heating. At the same time the remaining cycle time and the machine's overheating protection are shown on the left side in the form of two parallel scales. If the control button is pressed during the start-up sequence, the error code E3100 is displayed.

## Effect, cycle time, temperature settings, menu settings and info

### Cycle time A1100/A1200/A800

This is feature are only in models A1100/A1200 and the A800. The max cycle time for the A1100 is 10 minutes at max effect with a 5 minutes break between cycles. The max cycle time for the A800 is 20 seconds at max effect with a 10 second break between cycles. If a lower effect is applied, the cycle time increases in proportion to the reduction in the effect. The cycle time is shown on a scale on the left side of the display and is updated continuously during the cycle allowing the user to easily overview his work.

### Effect

The machine is automatically set at 100% effect. The effect range starts at 5% and max is 100%. If an alternative effect is required, set this using the arrow buttons on the right side of the display; a scale shows the decrease or increase of the setting in steps of 5%. It is also possible to adjust the effect in the settings menu by pressing the menu button and then setting the required effect numerically. The effect range returns to 100% when the machine is switched off.

### Temperature setting

Using the menu under the “TEMP” tab, the cooler effect can be set numerically in steps of 5°C by using the arrow buttons. Range from 5°C to 40°C. This setting is the only setting that is saved when the machine is turned in to standby mode.

### Menu settings

Using the menu under the “Power” tab, the effect can be set numerically in steps of 5% by using the arrow buttons. Range from 5% to 100%. The “Info” tab contains machine software variant, circuit boards software version and all circuit boards serial number information, which could be needed for possible updating.

### ProdTyp

This shows the machines software variant.

- A4000 software 40000000
- A1100 software 11000000
- A1200 software 12000000
- A800 software 08000000

### HwSwRev

This shows all the circuit boards different software versions. All files that are included in the bundle file.

- IcbHwRev
- IcbSwRev
- CcbHwRev
- CcbSwRev
- GfpHwRev
- GfpSwRev

### SerNo

This shows all circuit boards different serial number.



# Electric schedule all models

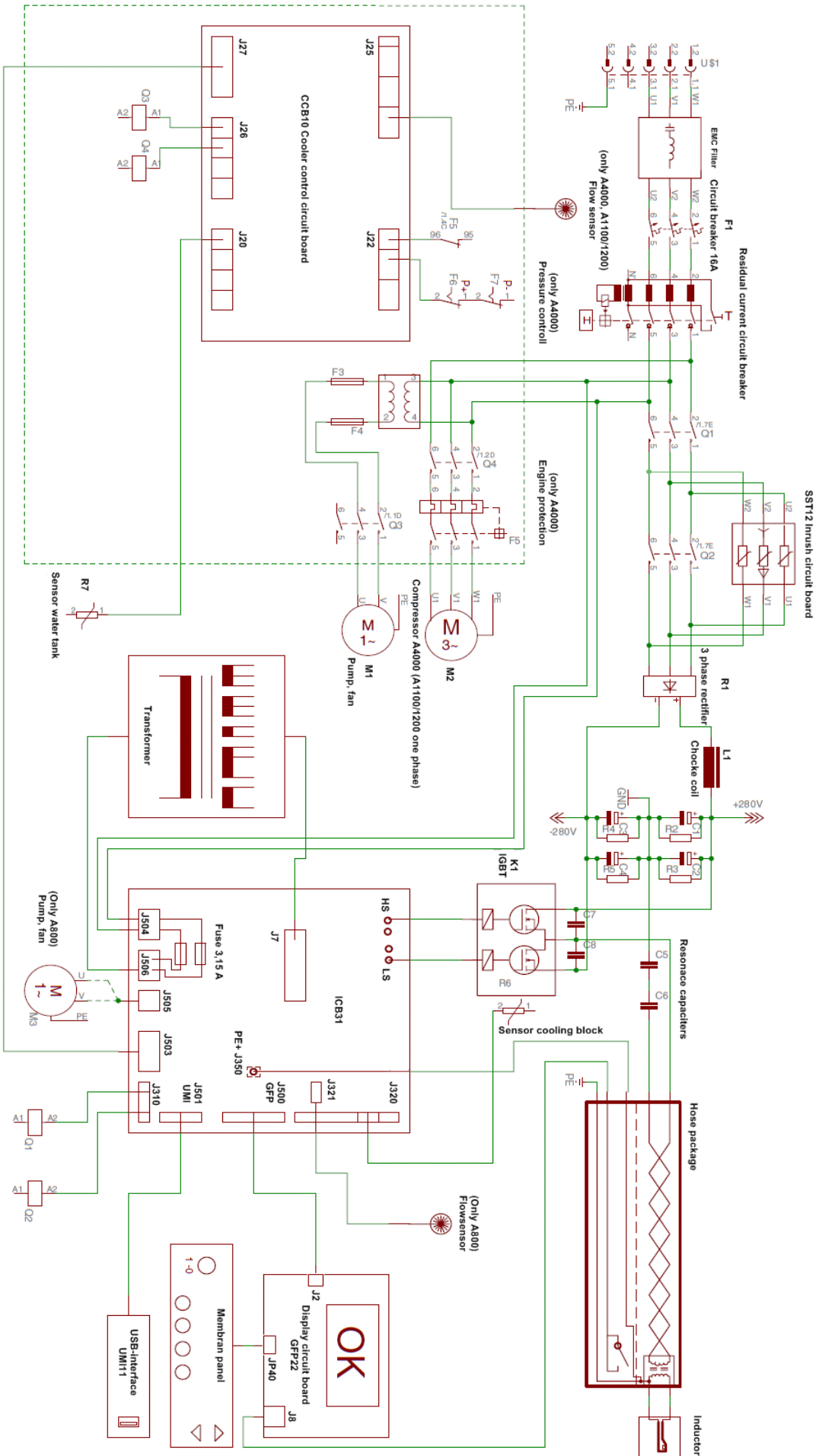

# Cooling block diagram

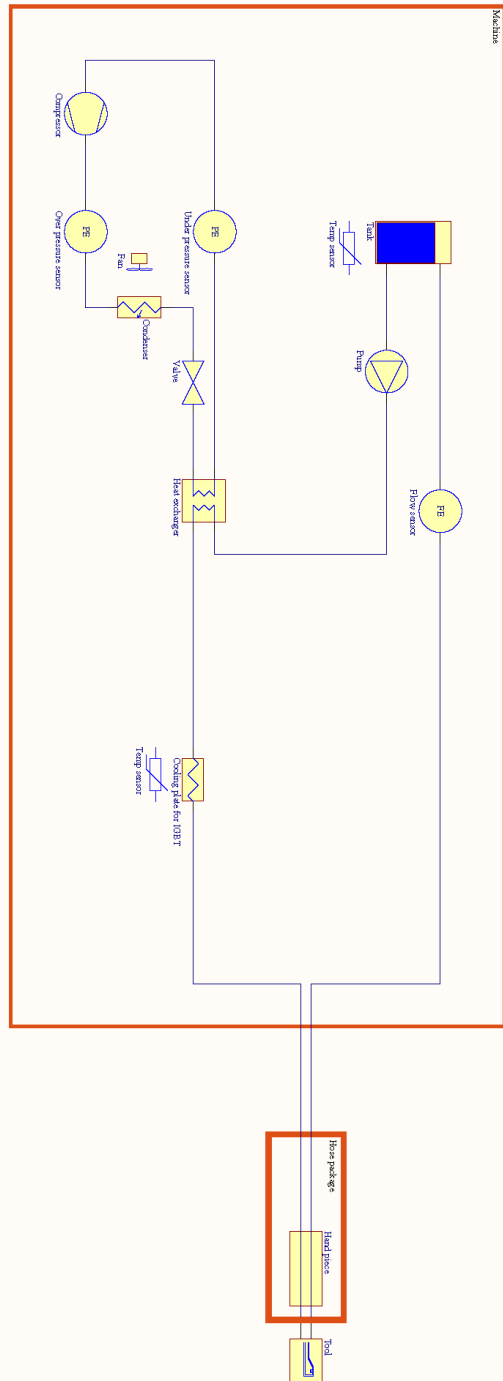

## Color indication on UMI11

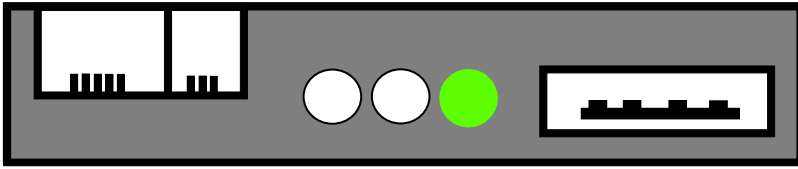

UMI11 showing power ok

### Ok messages during downloading:

Downloading \*bundle file (shows during downloading in ADiCS) ● ● ●

\*\*Do-file done ok (shows after successful downloading in ADiCS) ○ ● ●

### Error messages during downloading:

\*\*Do-file error (corrupt do file) ○ ● ●

Open \*bundle file failed (missing file name) ● ○ ○

Open \*\*do file failed (missing do file at the USB-stick) ○ ● ○

\*Bundle file corrupt (bundle faulty) ● ● ●

\*Bundle files loading failure (sync.) ● ● ●

\*Bundle files loading failure (loading) ● ● ●

General host error ○ ● ●

### Ok messages during single history downloading:

Single history downloading active ● ● ○

Single history downloading done ● ● ○

### Error messages during single history downloading:

Open single history file failed ● ● ○

Start of single history downloading failed ● ● ○

### Ok messages during continues history downloading:

Continues history downloading active ● ● ○

Continues history downloading done ● ● ○

### Error messages during continues history downloading:

Open continues history file failed ● ● ○

Start of continues history file downloading failed ● ● ○

\*Software for ADiCS

\*\*Do-file is one of up to three files at the USB-stick

## Troubleshooting

### Error codes A800/A1100/A1200/A4000

All three machines use the same error code system for a simple and fast trouble shooting. A4000 and A1100/A1200 have additional error codes because they are equipped with active coolers. Error codes that are critical need a full reset where the user/ technician need to unplug the machine from the mains.

<b>Problem</b>	<b>Cause</b>	<b>Corrective action / explanation</b>
<b>E1100</b>	Internal temperature too high at the cooling block	<ol style="list-style-type: none"><li>1. Check the water level in the water tank and then wait until the cooling cycle is finished.</li><li>2. The machine has overheated; wait until the cooling cycle is finished.</li></ol>
<b>E1110</b>	Internal temperature at the main board too high	<ol style="list-style-type: none"><li>1. Check that the ambient temperature is not over 40°C</li><li>2. Open the top lid and check if anything is stopping the air flow at the main board.</li></ol>
<b>E1200</b>	Coolant flow rate too low	<ol style="list-style-type: none"><li>1. Open the machine and check that no hoses are clamped.</li><li>2. Open the flow sensor and check that the flow sensor impeller rotates freely.</li><li>3. Remove the inductor and check that there is nothing obstructs the water flow.</li><li>4. Check the power cable that feeds the cooling unit from the heating unit.</li><li>5. Confirm the fault on the display and restart the machine.</li></ol>
<b>E3100</b>	Fault in the machine's PE+ protection	<ol style="list-style-type: none"><li>1. Visually check that the hose package and the earth and PE+ cables are intact and in place.</li><li>2. Confirm the fault on the display. If the fault reoccurs without there being any visible signs of damage, contact Alesco International AB immediately.</li></ol>
<b>E3110</b>	Trigger switch error	<ol style="list-style-type: none"><li>1. Trigger switch stuck. Check that the trigger switch isn't activated when the machine starts up.</li><li>2. Measure the trigger switch and replace if faulty.</li><li>3. Check if the rubber cap at the trigger switch is correct and without any damage.</li><li>4. Check that the trigger switch isn't blocked by the trigger switch holder.</li><li>5. Measure the trigger switch cable and replace if its short circuit.</li><li>6. Disconnect the heater from the mains supply for full reset.</li></ol>

<b>Problem</b>	<b>Cause</b>	<b>Corrective action / explanation</b>
<b>E4100</b>	Defective hose package or power unit (transistor)	<ol style="list-style-type: none"> <li>1. Disconnect the hose packages two black cables under the protective lid. Reset the error code by disconnect the mains and test again.</li> <li>2. If the error code reappears the fault is in the transistor or the main board. To check the transistor disconnect the copper contacts at the transistor and measure it.</li> <li>3. If the transistor is faulty change it and test it as in point 1.</li> <li>4. If the error code doesn't appears the fault is in the hose package. Measure the hose package with an isolation meter and change the hose package.</li> </ol>
<b>E4199</b>	General hardware error	<ol style="list-style-type: none"> <li>1. Check the machine for any visible signs of damage.</li> <li>2. Check the cooling unit for any visible signs of damage.</li> <li>3. Contact Alesco International AB for support</li> </ol>
<b>E4410</b>	Compressor motor overload protection	<ol style="list-style-type: none"> <li>1. Check that nothing is obstructing the air flow for the cooling unit and reset the compressor motor overload protection inside the electrical box. If the error code is displayed the user has to do a manual reset of the compressor motor overload protection and disconnect the heater from the mains supply for full reset.</li> <li>2. Check that the radiator isn't clogged with dirt. If it is clean the radiator with compressed air. NOTE! Don't get to close with the air nozzle. Then do a reset as described in point 1.</li> </ol>
<b>*E4420</b>	Cooler pressure to high (Only at A4000)	High pressure guard activated. Contact a cooling technician to have the cooling unit checked.
<b>*E4421</b>	Cooler pressure to low (Only at A4000)	Low pressure guard activated. Contact a cooling technician to have the cooling unit checked and pressurized.
<b>E4601</b>	Communication error between machine and display board (GFP).	Restart machine if fault still present. Check the cable between the boards. Check the connectors.
<b>E4602</b>	Communication error (Only at A4000 and A1100/A1200). Communication error between machine and cooler.	<ol style="list-style-type: none"> <li>1. Check the CCB11. Open the electrical box inside the cooling unit and check visually at the CCB11 that the LED at the TP1 test point is on.</li> <li>2. If the LED isn't on check the connection cables between the CCB11 and the ICB31. Change if necessary.</li> <li>3. If the LED is on, download new software to the ADiCS and restart the machine.</li> <li>4. If step 2, 3 didn't help change the CCB11 circuit board and download new software to the ADiCS and restart the machine.</li> </ol>

## Malfunctions

<b>Problem</b>	<b>Cause</b>	<b>Check procedure/corrective measure</b>
The inductor gets hot, and sparks may jump between the inductor and the transformer.	Poor connection. The inductor bolts are loose. Dirt between the inductor and transformer.	Disconnect the induction heater from the mains supply. Clean the contact surfaces on both the inductor and the transformer. Tighten the bolts
Water leak at the inductor.	O-rings damaged or the inductor is worn out.	Replace the O-rings or the inductor.
The hose package is leaking water.	The hose package is damaged.	Disconnect the induction heater from the mains supply. Change the hose package.
The transformer mounted at the hose package is leaking water at the soldering edges	The transformer housing is damaged.	Disconnect the induction heater from the mains supply. Change the hose package.
One or more screws have gone off.	Overheating the screws because the inductor hasn't been properly fastened	Disconnect the inductor and unscrew the damaged screw. Refit the inductor with new screws.
One or more threads in the transformer has followed the screw up during disassembly of the inductor	Overheating in the threads because the inductor hasn't been properly fastened	Refit new threads and mount the inductor properly.
Sparks jump between the inductor and the work piece.	Worn inductor.	Order a new inductor from your dealer or Alesco International AB.
Crack formation in the inductor	Overheated work piece has caused the field amplifier to crack.	Order a new inductor from your dealer or Alesco International AB.
The machine does not provide heat.	The inductor is not properly secured	Disconnect the induction heater from the mains supply. Clean the contact surfaces. Tighten the bolts
The machine does not provide heat.	Something in the high voltage line is broken	<ul style="list-style-type: none"> <li>• Check the contact block, the copper rail and the connectors for the black cables from the hose package at cooling block.</li> <li>• Check the chock coils connectors at the capacitor battery and at the rectifier bridge.</li> <li>• Check all cables and connectors at the capacitor bridge.</li> <li>• Check the resonance capacitors.</li> <li>• Check the rectifier bridge.</li> </ul>

Problem	Cause	Check procedure/corrective measure
When the trigger switch is pressed the user feels an electric sensation.	<ul style="list-style-type: none"> <li>The trigger switch's rubber cap is damage or missing.</li> <li>The trigger switch cable isolation is worn or missing.</li> <li>One or both soldering points inside the trigger switch are not properly connected.</li> </ul>	<ul style="list-style-type: none"> <li>Change the defective trigger switch.</li> <li>Change the defective cable.</li> <li>Open the trigger switch and solder on the loose connection.</li> </ul>
The control panel and/or start/standby button do not light up and the LED at the USB port is off.	<ul style="list-style-type: none"> <li>The induction heater is not connected to the mains supply.</li> <li>No electricity at the wall socket or the main fuse has tripped.</li> <li>Loose connections in the plugs or wall socket</li> <li>Break in the extension cable if there is one</li> </ul>	<ul style="list-style-type: none"> <li>Connect the induction heater to the wall socket.</li> <li>Reset the fuse and check the connecting cable.</li> <li>Contact an authorised electrician.</li> <li>Replace the defective cable.</li> </ul>
The control panel and/or start/standby button do not light up but the LED at the USB port is showing green	<ul style="list-style-type: none"> <li>The membrane panel is defective</li> <li>The GFP22 has lost its software or is defective.</li> </ul>	<ul style="list-style-type: none"> <li>Change the membrane panel.</li> <li>Update the software see "Updating the software" chapter and restart the machine when done.</li> <li>Change the GFP22 and update the software see chapter "Updating the software"</li> </ul>
All three phases are ok but the machine doesn't start at all.	<ul style="list-style-type: none"> <li>One or both fuses at the ICB31 are broken.</li> <li>The transformer inside the machine is not providing correct voltage.</li> <li>The ICB31 doesn't get correct feed at J504</li> </ul>	<ul style="list-style-type: none"> <li>Measure the fuses and change if required.</li> <li>Measure the transformer connections see chapter "Interface ICB31".</li> <li>Measure the connection J504.</li> </ul>
The control panel buttons do not work	The button unit is defective	Change the membrane panel.
Abnormal noise	Something is lodged against the fan	Remove the mains cable, open the machine and check for something lodged in the fan. <b>NOTE! Wait until the fan stops.</b>

## Spare parts

### Base A800/A1100/A1200/A4000

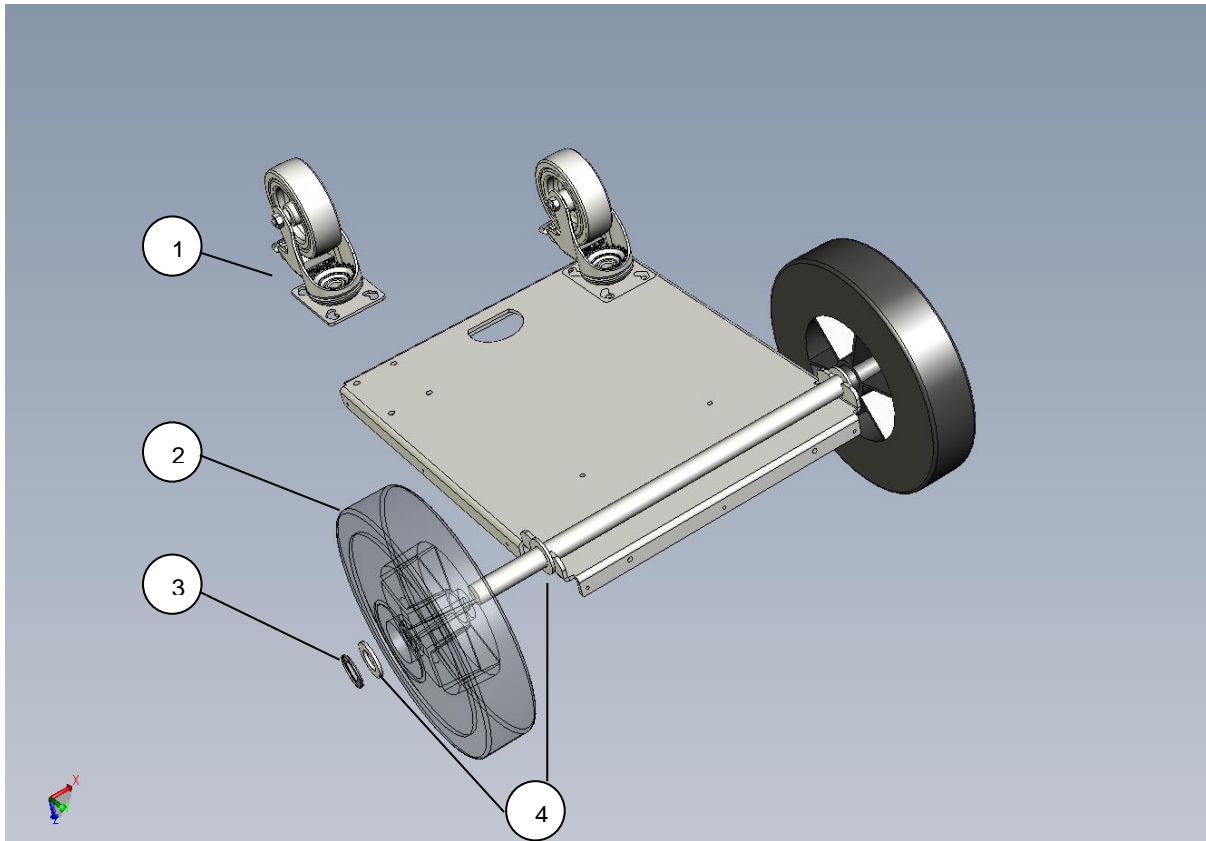

- |                  |                          |
|------------------|--------------------------|
| 1. Forward wheel | 100626 2 pc.             |
| 2. Rear wheel    | 100079 2 pc.             |
| 3. Star lock     | 100385 2 pc.             |
| 4. Washer        | 100654 4 pc / 2 pc A4000 |



## Cooling unit A800

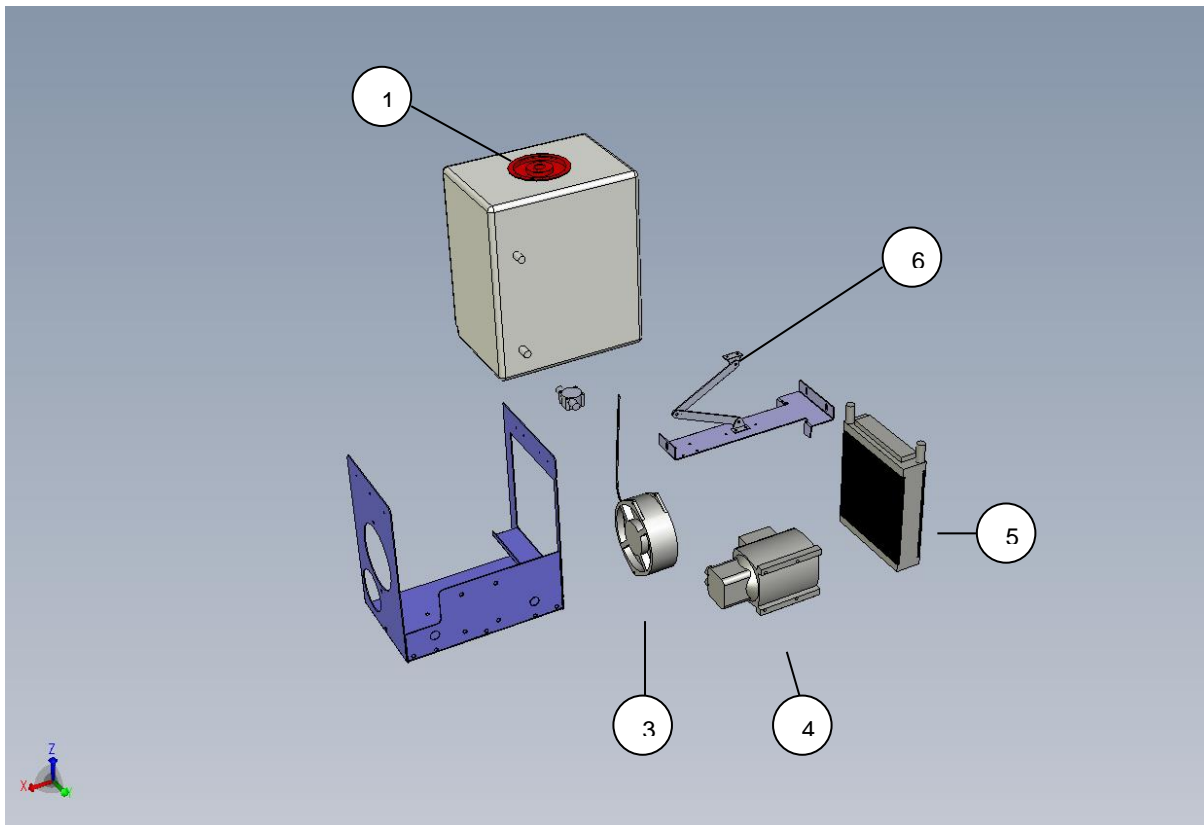

1. Lid	100428 1 pc.
2. Flow sensor	100360 1 pc.
3. Fan	100068 1 pc.
4. Water pump	100284 1 pc.
5. Condenser	100069 1 pc.
6. Lock arm	100540 1 pc.

## Cooling Unit A1100/A1200

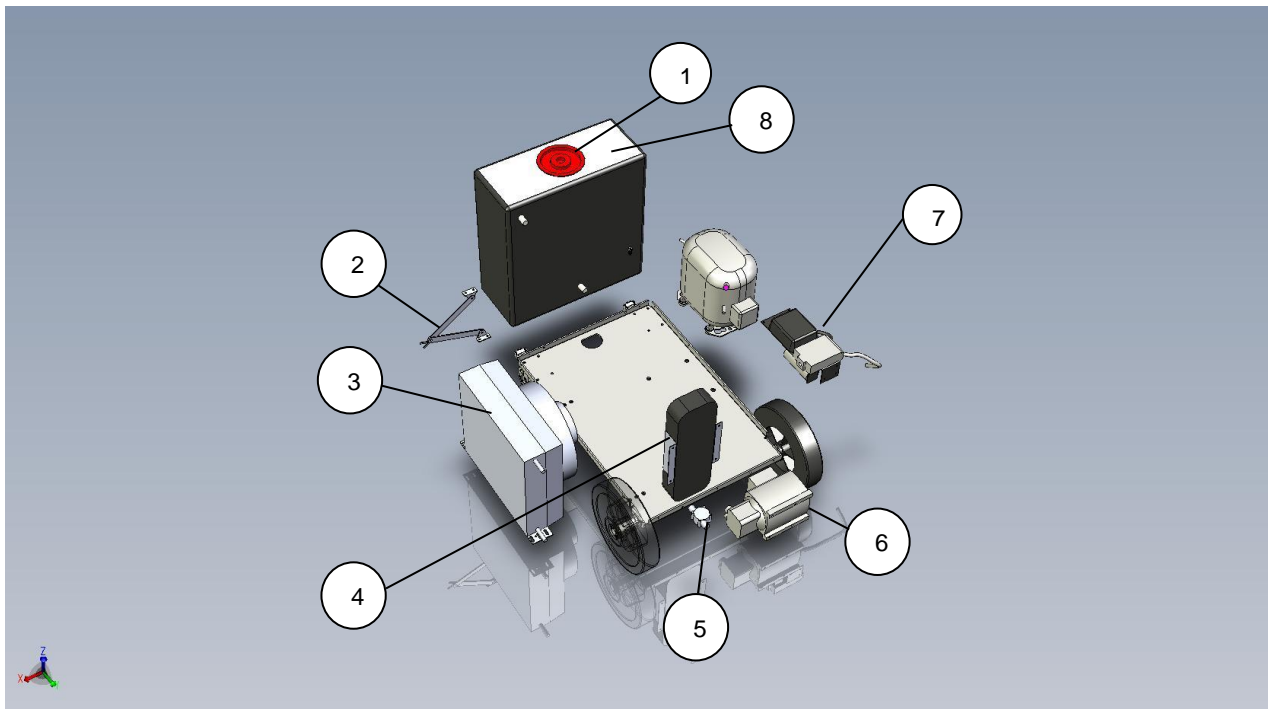

1. Lid	100428 1 pc.
2. Lock arm	100540 1 pc.
3. Fan condenser	100533 1 pc.
4. Intercooler	100537 1 pc.
5. Flow sensor	100360 1 pc.
6. Water pump	100284 1 pc.
7. Compressor/electric unit	100534 1 pc. SC15DL
8. NTC sensor	100406 1 pc.

## Cooling Unit A4000 P1

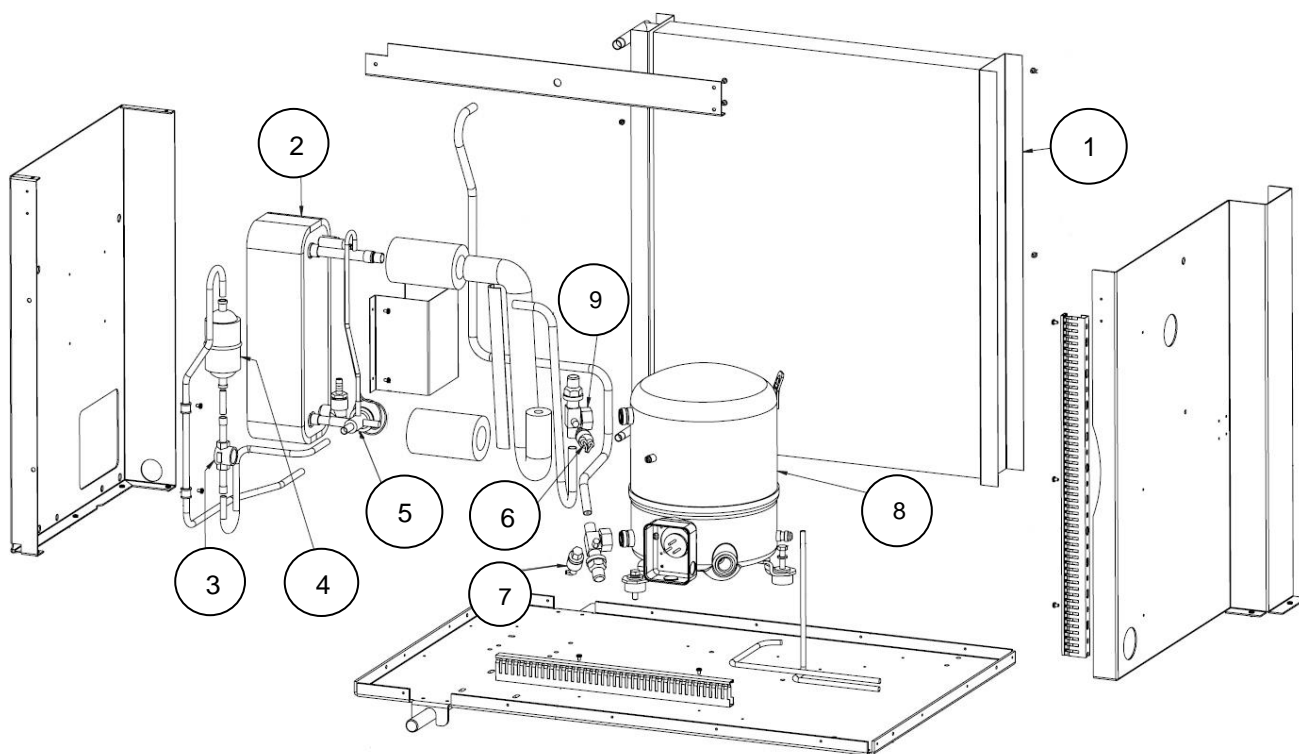

1. Condenser	100522 1 pc.
2. Intercooler	100525 1 pc.
3. Liquid indicator	100518 1 pc.
4. Filter	100519 1 pc.
5. Expansion valve	100517 1 pc.
6. High pressure switch	100524 1 pc.
7. Low pressure switch	100523 1 pc.
8. Compressor	100520 1 pc. MTZ028-4VI
9. Rotalock valve 1-1/2" (V06)	100521 2 pc

## Cooling Unit IS4000 P2

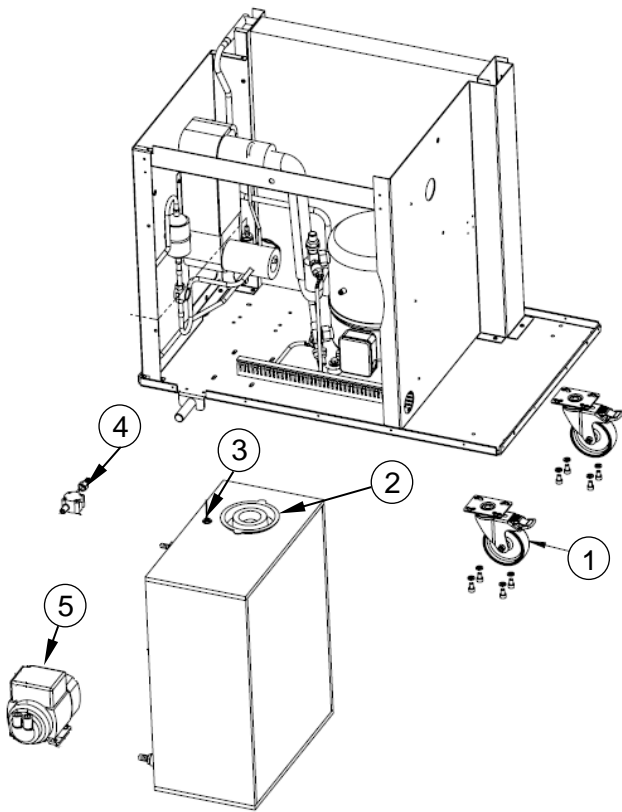

- |                  |              |
|------------------|--------------|
| 1. Forward wheel | 100626 2 pc. |
| 2. Lid           | 100428 1 pc. |
| 3. NTC sensor    | 100406 1 pc. |
| 4. Flow sensor   | 100360 1 pc. |
| 5. Water pump    | 300170 1 pc. |

## Cooling Unit IS4000 P3

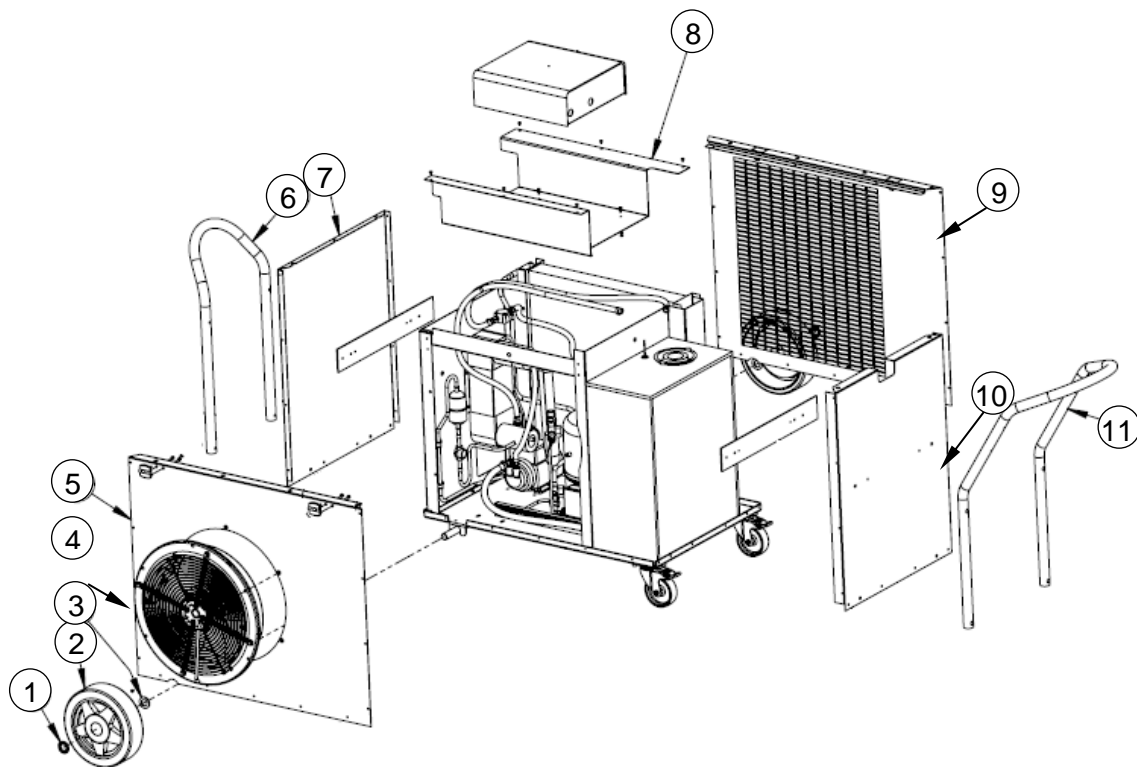

1. Star lock	100385 2 pc.
2. Rear wheel	300110 2 pc.
3. Washer	300111 2 pc.
4. Fan	100526 1 pc.
5. Right side plate	100546 1 pc.
6. Rear handle	100512 1 pc.
7. Rear plate	100544 1 pc.
8. Inside top plate	100545 1 pc.
9. Left side plate	100547 1 pc.
10. Front plate	100548 1 pc.
11. Front handle	100511 1 pc.

## Electrical box cooling unit A1100/A1200/A4000

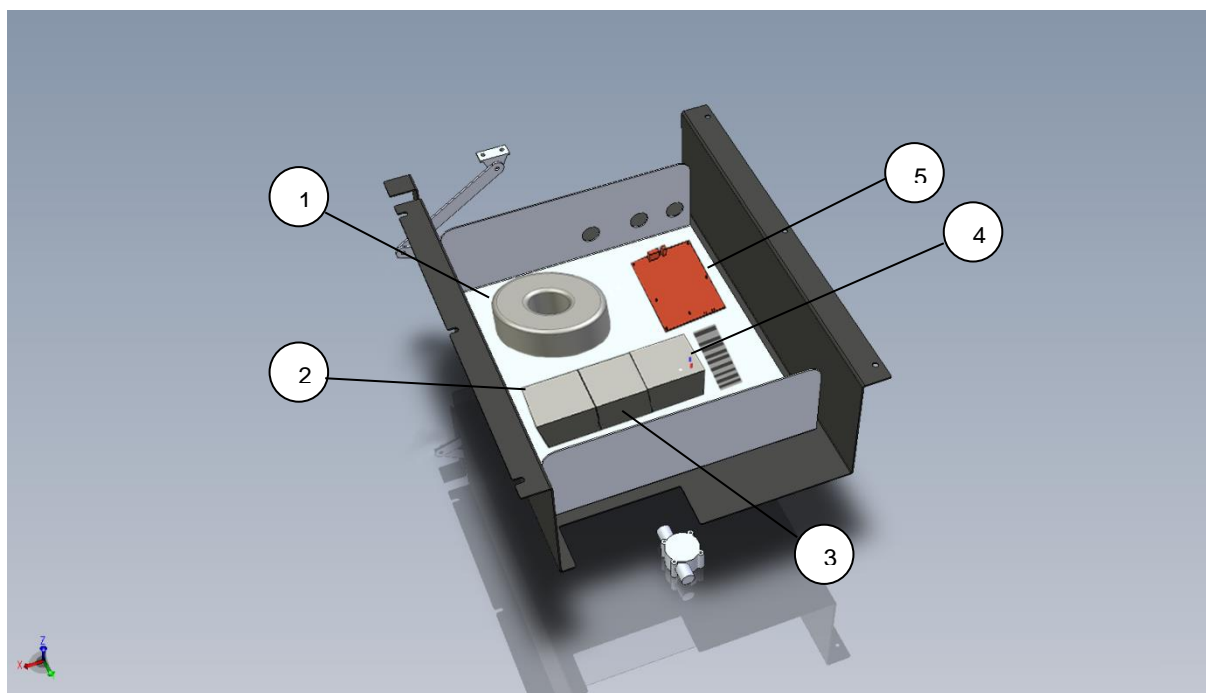

1. Transformer	100465 1 pc.
2. Contactor K1	100391 1 pc.
3. Contactor K2	100391 1 pc.
4. *Automatic circuit breaker	100494 1 pc.
5. KK CCB10	100434 1 pc.

\* Only in A4000

## Hose package cover, guide and contact rail A800/A1100/A1200/A4000

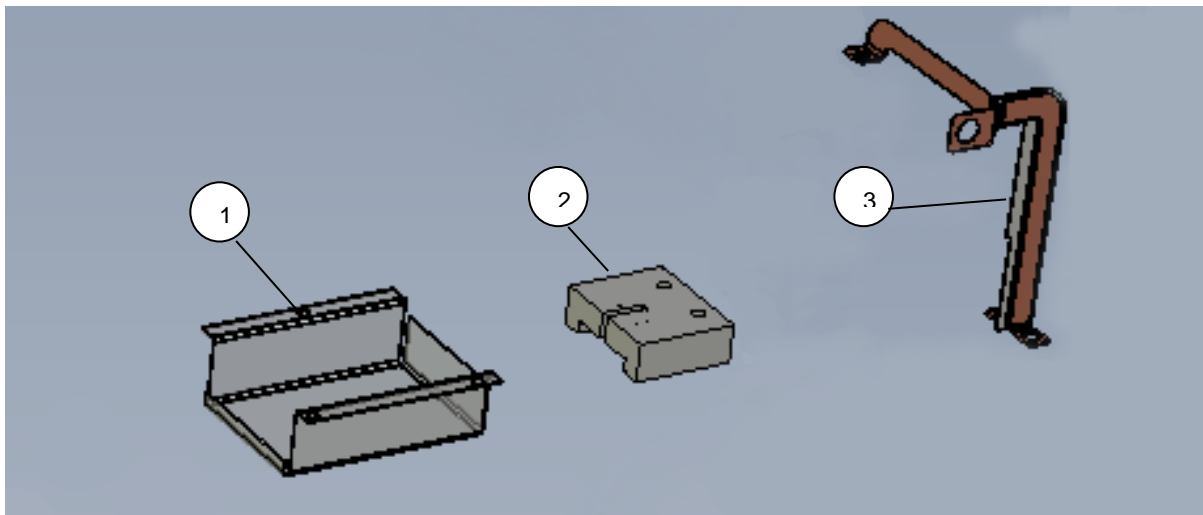

- |                  |              |
|------------------|--------------|
| 1. Cover lid     | 100460 1 pc. |
| 2. Contact block | 100404 1 pc. |
| 3. Contact rail  | 100598 1 pc. |

## Hose package section A800/A1100/A1200/A4000

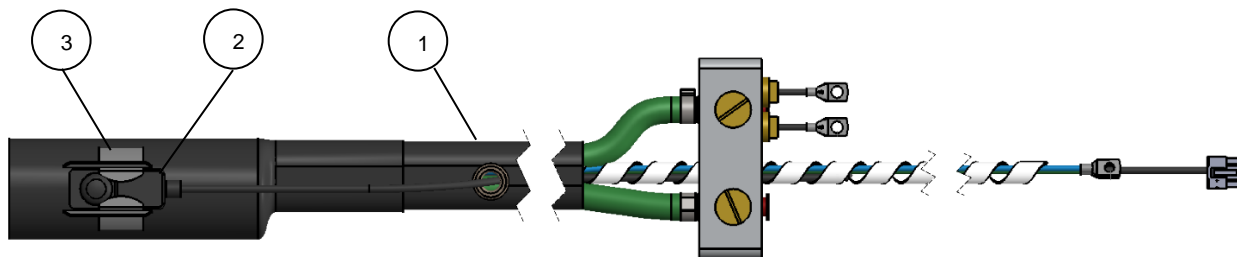

- |                                    |   |
|------------------------------------|---|
| 1. Hose package A800               | 100415 1 pc. (O-rings, screws included) |
| Hose package A1100/A1200           | 100586 1 pc. (O-rings, screws included) |
| Hose package A4000                 | 100586 1 pc. (O-rings, screws included) |
| 2. Trigger switch                  | 100028 1 pc.                            |
| 3. Switch holder A1100/A1200/A4000 | 100051 1 pc.                            |
| 4. Switch holder A800              | 100610 1 pc.                            |

## Top section A800

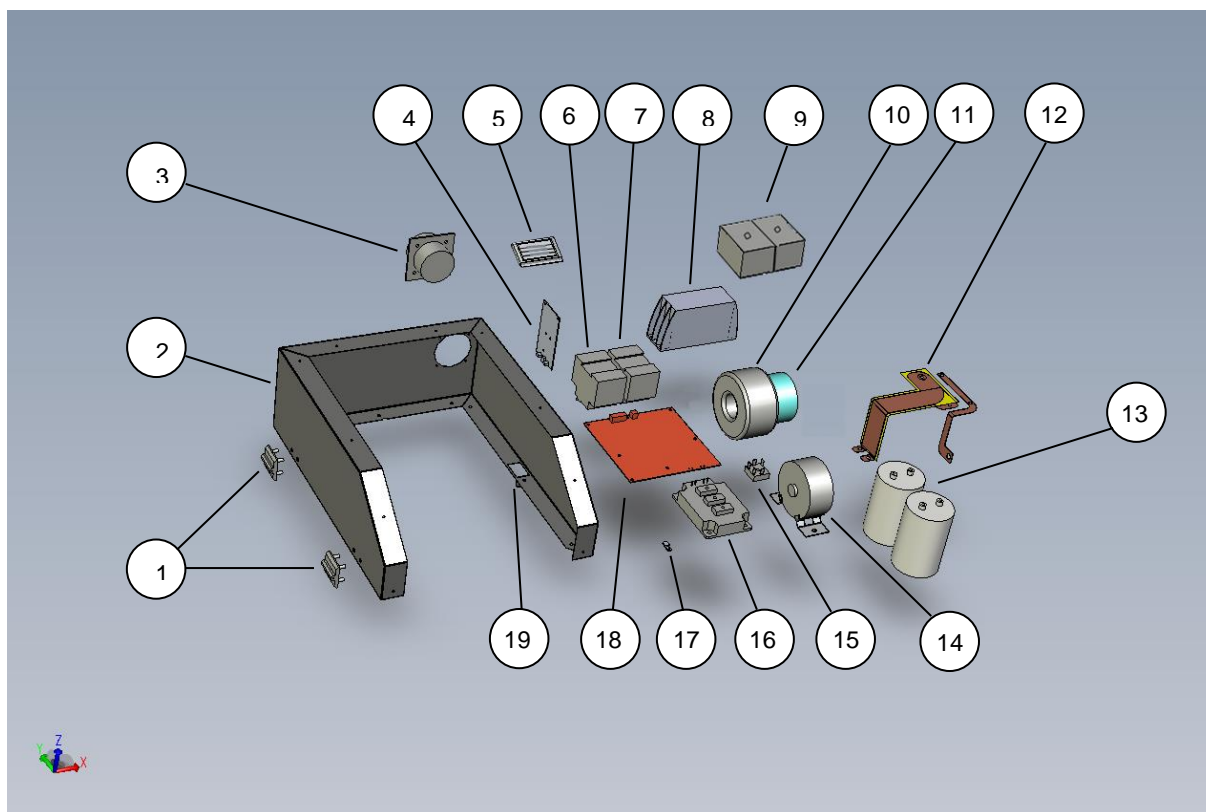

1. Hinge	100467 2 pc.	12. Contact rails	100450 1 pc.
2. Top cover	100457 1 pc.	13. Capacitors	100202 2 pc.
3. Mains 16A	100390 1 pc.	14. Resonance cap.	100047 1 pc.
4. KK UMI11	100402 1 pc.	15. Rectifier	100040 1 pc.
5. KK SST12	100648 1 pc.	16. Transistor	100333 1 pc.
6. Main fuse 16A	100178 1 pc.	17. NTC sensor	100406 1 pc.
7. RCD	100380 1 pc.	18. ICB31	100400 1 pc.
8. Filter	100381 1 pc.	19. Lock	100572 1 pc.
9. Contactors	100391 2 pc.		
10. Transformer	100345 1 pc.		
11. Choke coil	100212 1 pc.		



## Top section A1100/A1200/A4000

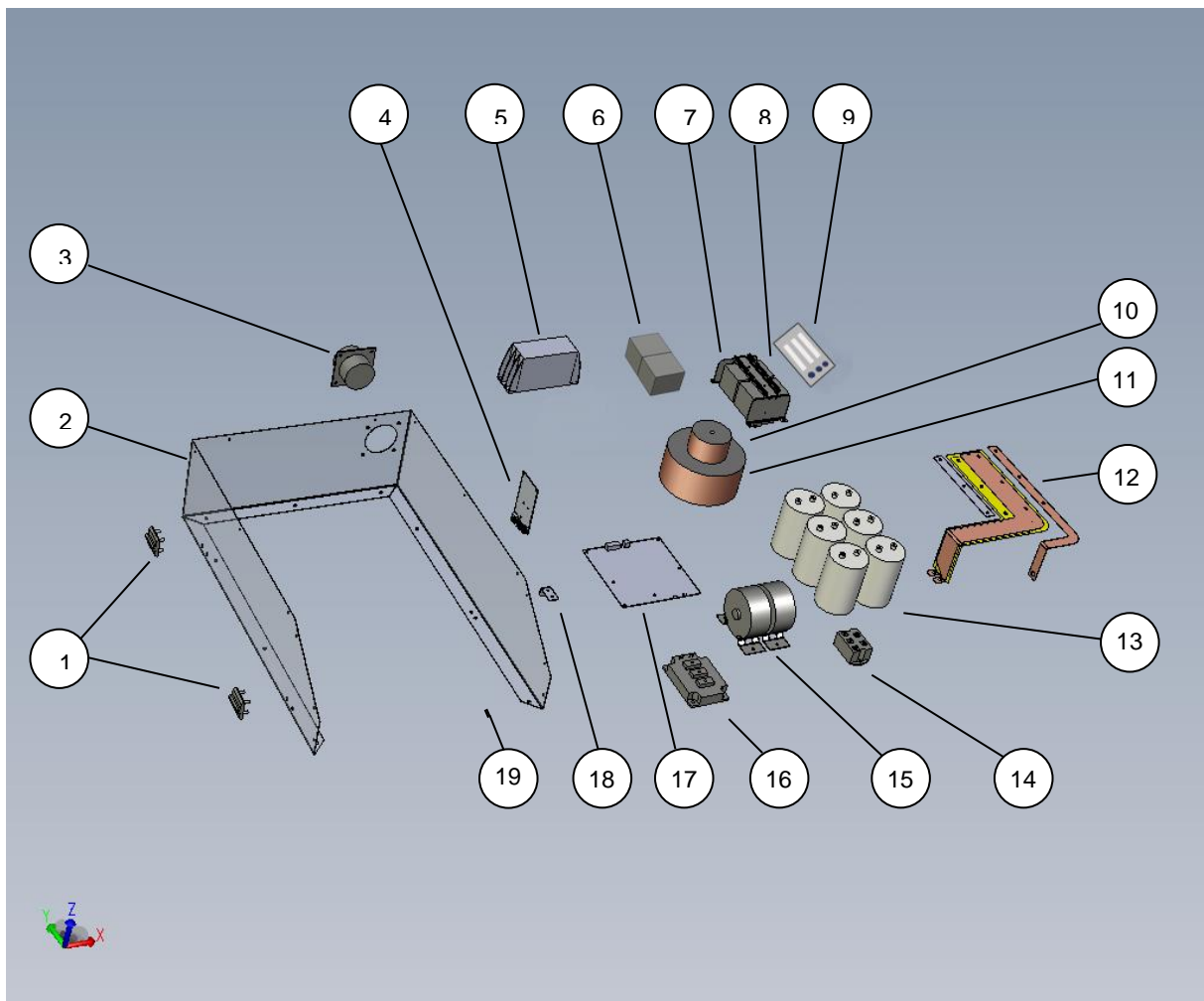

1. Hinge	100467 2 pc.	10. Transformer	100345 1 pc.
2. Top cover	100457 1 pc.	11. Choke coil	100212 1 pc.
3. Mains A1100 16A	100390 1 pc.	12. Contact rails	100552 1 pc.
Mains A1200 16A	100390 1 pc.		100553 1 pc.
Mains A4000 32A	100507 1 pc.		100554 1 pc.
4. UMI11	100402 1 pc.		100646 1 pc.
5. Filter	100381 1 pc.	13. Capacitors	100202 6 pc.
6. Contactor A1100 16A	100391 2 pc.	14. Rectifier	100059 1 pc.
Contactor A1200 16A	100391 2 pc.	15. Resonance cap.	100047 2 pc.
Contactor A4000 32A	100508 2 pc.	16. Transistor	100333 1 pc.
7. Main A1100 fuse 16A	100178 1 pc.	17. KK ICB31	100400 1 pc.
Main A1200 fuse 16A	100178 1 pc.	18. Lock	100572 1 pc.
Main A4000 fuse 32A	100268 1 pc.	19. NTC sensor	100406 1 pc.
8. RCD	100380 1 pc.		
9. KK SST12	100648 1 pc.		

## Top A800/A1100/A1200/A4000

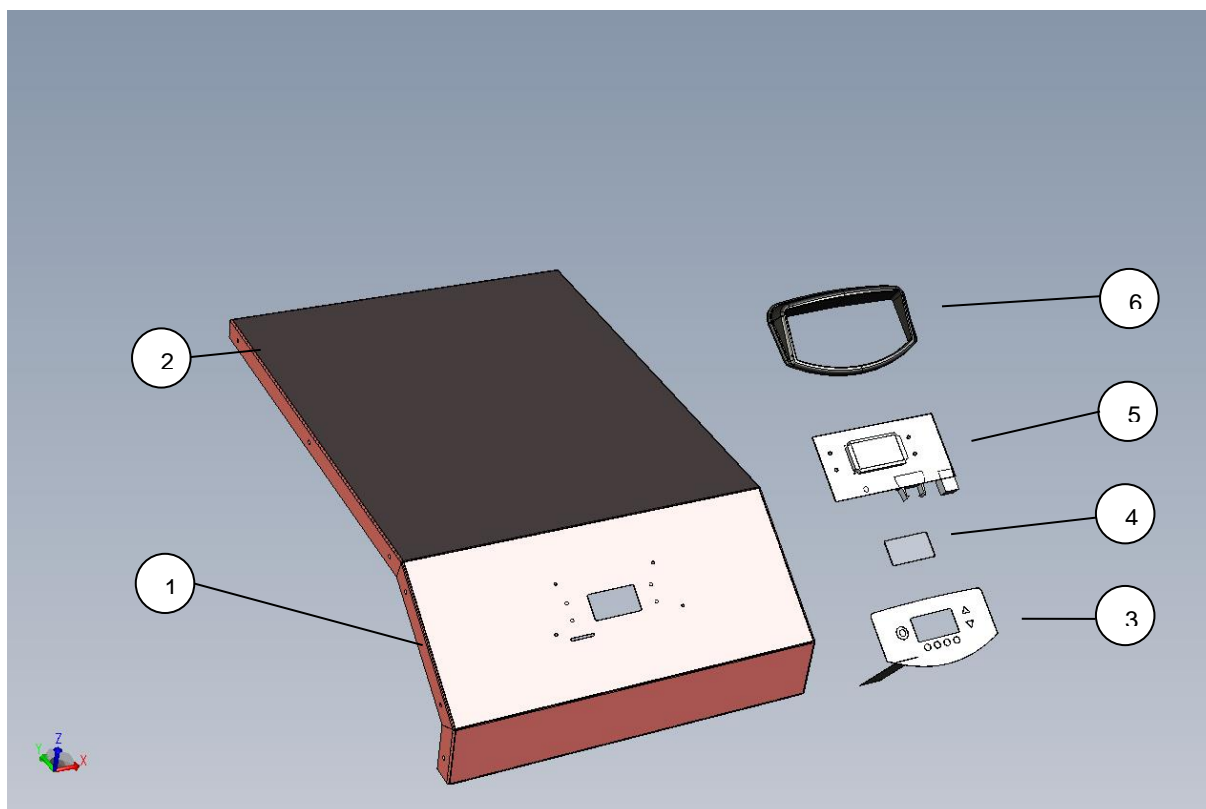

1. Top lid A800	100458 1 pc.
Top lid A1100	100569 1 pc.
Top lid A1200	100569 1 pc.
Top lid A4000	100550 1 pc.
2. Rubber Carpet A800	100499 1 pc.
Rubber Carpet A1100	100590 1 pc.
Rubber Carpet A1200	100590 1 pc.
Rubber Carpet A4000	100560 1 pc.
3. Membrane panel	100382 1 pc.
4. Plastic plate	100466 1 pc.
5. KK GFP2	100401 1 pc.
6. Panel protection	100559 1 pc.

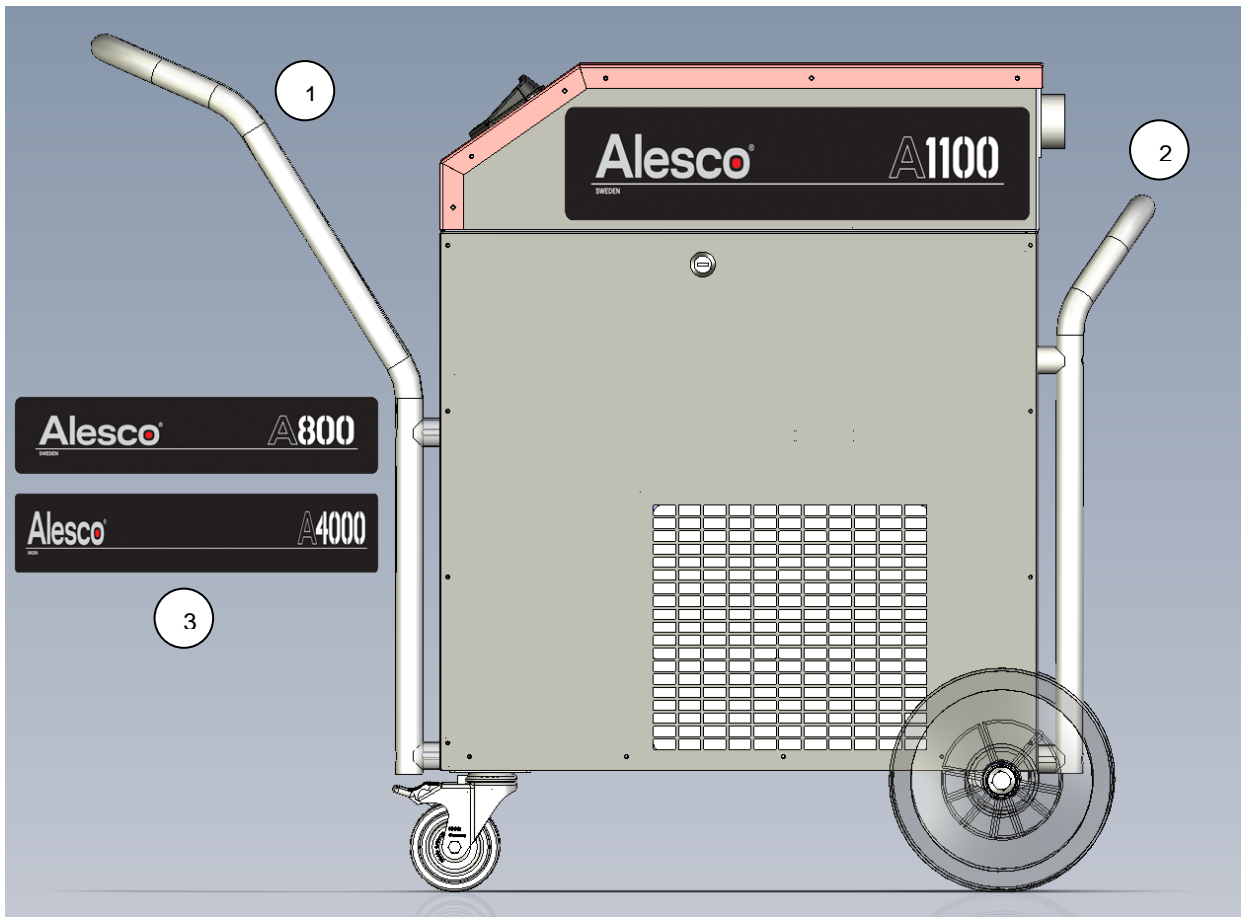

### Handles, stickers and mains cable A800/ A1100/A1200

1.	Front handle A800	100430 1 pc.
	Front handle A1100/A1200	100430 1 pc.
2.	Rear handle. A800	100431 1 pc.
	Rear handle. A1100/A1200	100431 1 pc.
3.	Sticker A800	100500 1 pc.
	Sticker A1100	100501 1 pc.
	Sticker A1200	900802 1 pc.
	Sticker A4000	100502 1 pc.
4.	*16A Mains cable A800/A1100/A1200	100409 1 pc.
5.	*32A Mains cable A4000	100486 1pc.
	*Not in picture	

## Connections at the circuit boards P30

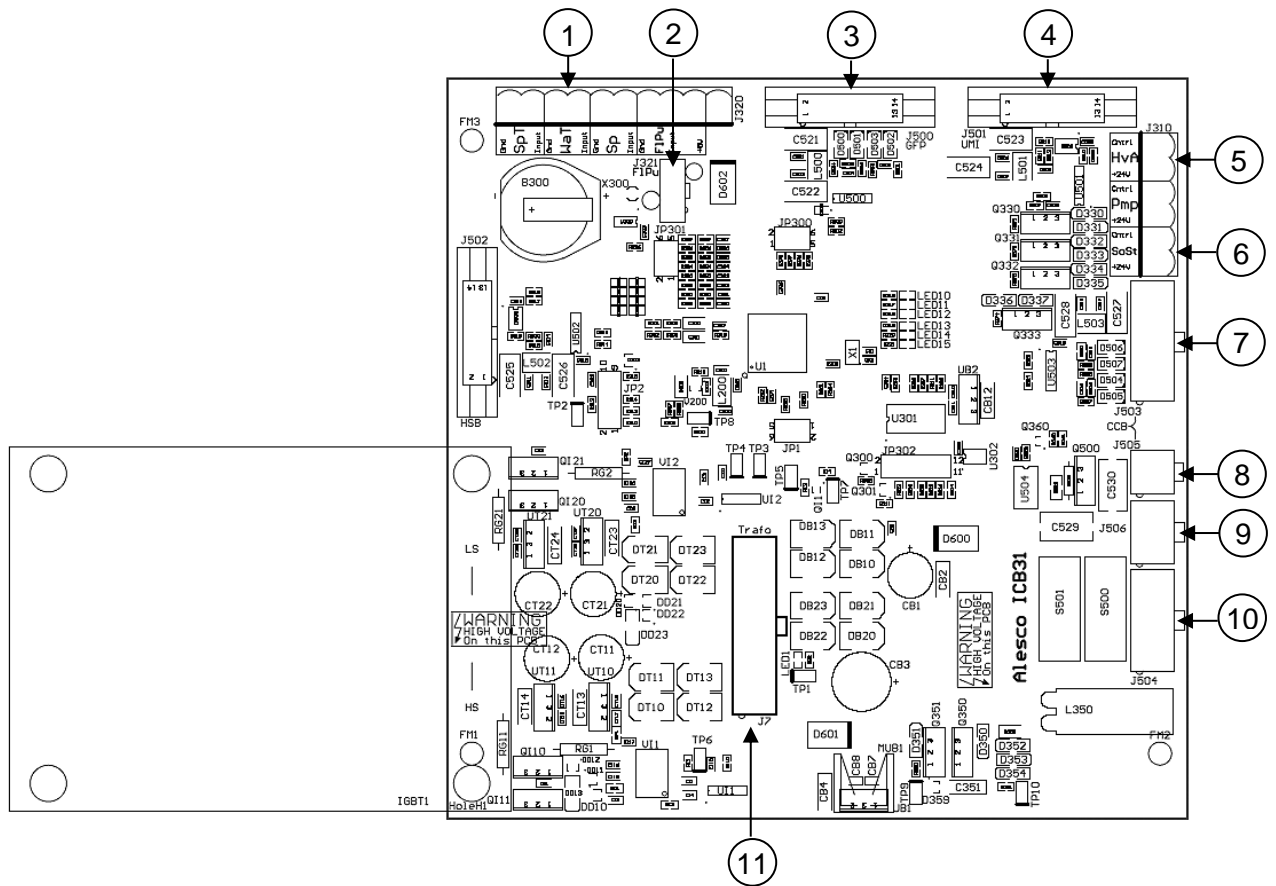

### Precautions

- When handling PCBs do not touch PCB connectors with your bare skin or damage them.
- Do not allow PCBs with ICs mounted on them to come in contact with bare skin or other items with a static charge.
- Protect PCBs with ESD protective bags etc.

### ICB31

Position	Description
1	Temp sensor cooling block
2	Flow sensor
3	GFP22 Display interface
4	UMI11 USB interface
5	Contactor K1 Soft start connect
6	Contactor K2 Soft start override
7	Communication cooler, not in use A800
8	220V Cooling unit A800, not in use A1100, A4000
9	Transformer in put
10	220V feed
11	Transformer out put

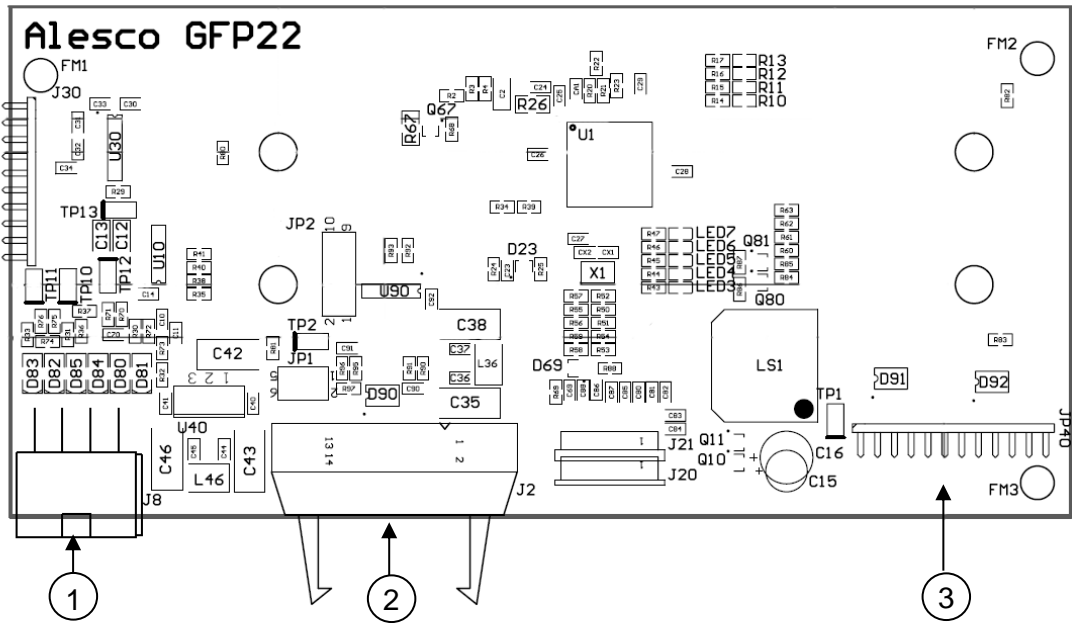

GFP22

Position	Description
1	Trigger switch
2	ICB31 J500
3	Membrane panel

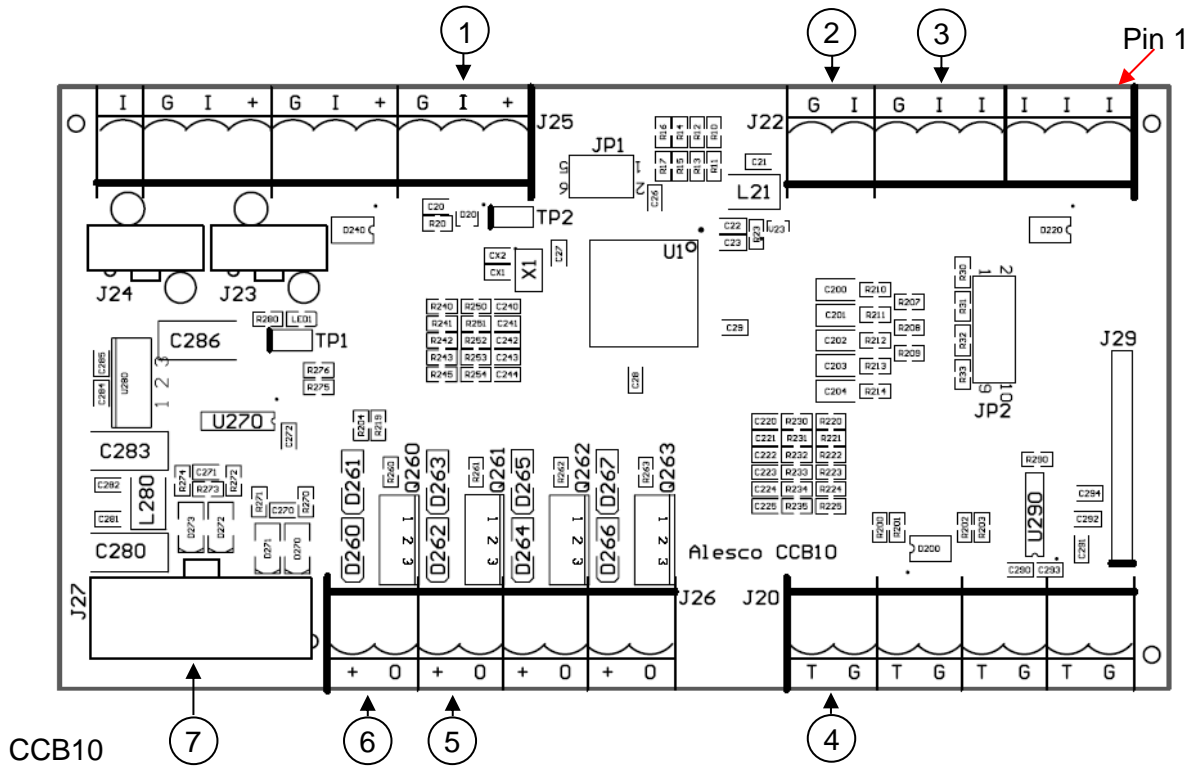

Position	Description
1	Flow sensor (A4000/A1200/A1100)
2	Compressor motor overload protection (A4000)
3*	High and low pressure guards (A4000)
4	Water temperature tank sensor
5	Water pump contactor
6	Compressor contactor
7	Communication cooler

\*Pin 4 Low pressure/Pin 5 High pressure/ Pin 7 Engine protection

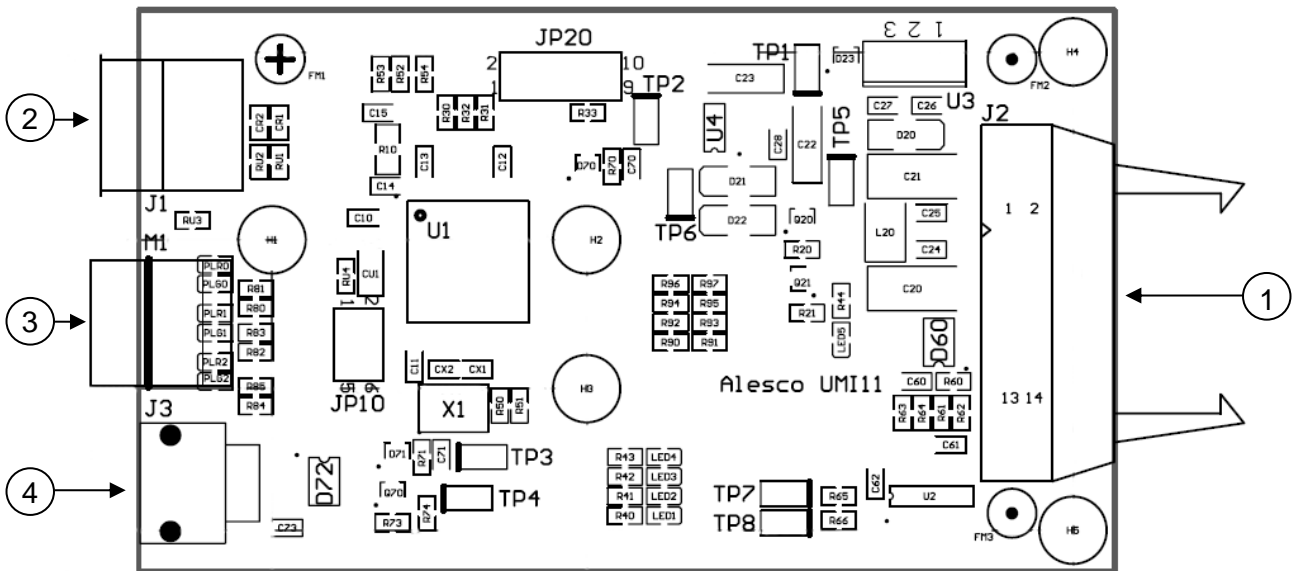

UMI11

Position	Description
1	ICB31
2	USB interface
3	Information LED:s
4	UMPA10 interface

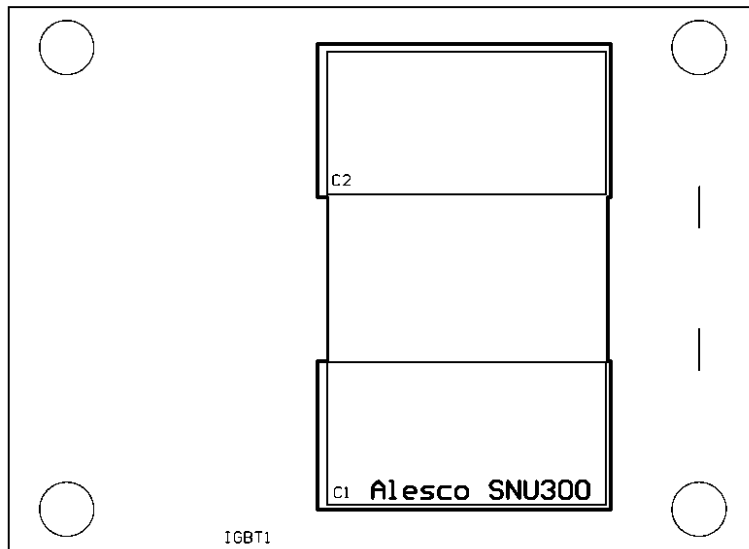

SNU300

Position	Description
1	SNU300

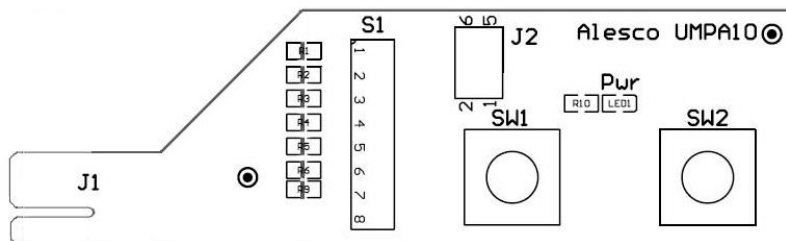

UMPA10

Position	Description
1	UMPA10



## Interface ICB31

J7

Pin	Color	Function
1	Green	17 V
10	Grey	0 V
11	Green	17 V
4	White	24 V
5	White	0 V
14	Orange	7.5 V
15	Orange	0 V
8	Blue	17 V
9	Purple	0 V
18	Blue	17 V
Remaining	Not in use	-

J506

Pin	Color	Function
1	Black	400 V
4	Yellow	400 V
2	Not in use	-
5	Not in use	-
3	Black	230 V
6	Brown	230 V

\*J505 Pump control

Pin	Color	Function
1	Not in use	-
2	Blue	230 V
3	Blue	230 V
4	Not in use	-

\*only in use A800

J504

Pin	Color	Function
1	Grey	400 V
6	Not in use	-
3	White	400 V
8	Not in use	-
Remaining	Not in use	-

J310

Pin	Color	Function
1	Yellow	+24 V
2	Green	GND
5	Yellow	+24 V
6	Green	Earth
Remaining	Not in use	-

J320

Pin	Color	Function
7	Black	Signal
8	Black	Earth
Remaining	Not in use	-

J321

Pin	Color	Function
1	Red	+5V
2	White	Input
3	Black	Earth

## Interface CCB10

J20

Pin	Color	Function
1	Black	Temp signal
2	Black	Temp earth
3	-	Not in use
4	-	Not in use
5	-	Not in use
6	-	Not in use
7	-	Not in use
8	-	Not in use

J22

Pin	Color	Function
1	-	Not in use
2	-	Not in use
3	-	Not in use
4	-	Not in use
5	-	Signal
6	-	Earth
7	-	Signal
8	-	Earth

J25

Pin	Color	Function
1	Red	+5V
2	White	Input
3	Black	Earth

J26

<b>Pin</b>	<b>Color</b>	<b>Function</b>
1	Yellow	+24V Contactor 1
2	Green	Earth Contactor 1
3	Yellow	+24V Contactor 2
4	Green	Earth Contactor 2
5	-	Not in use
6	-	Not in use
7	-	Not in use
8	-	Not in use

J27

<b>Pin</b>	<b>Color</b>	<b>Function</b>
1	-	Communication heater

# Measuring and checking hardware.

**NOTE! High voltage area!**

## Checking the rectifier:

A4000/A1100/A1200 Rectifier SKD 62/16

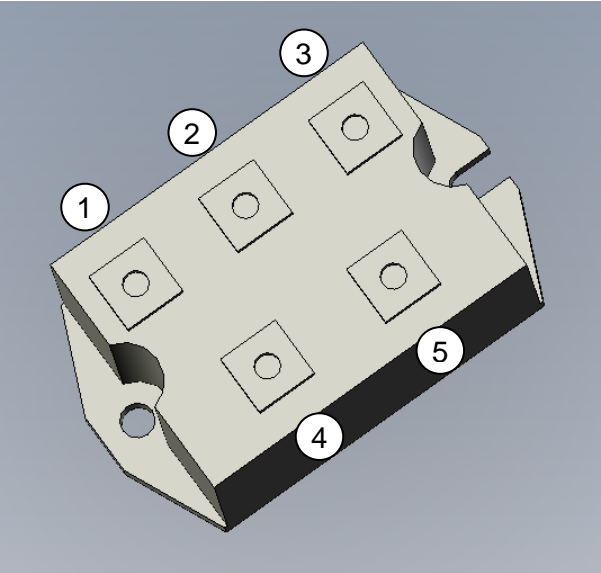

Between position 1-3 390-400VAC  
Between position 4-5 530-560VDC

A800 Rectifier SKD 26MT120

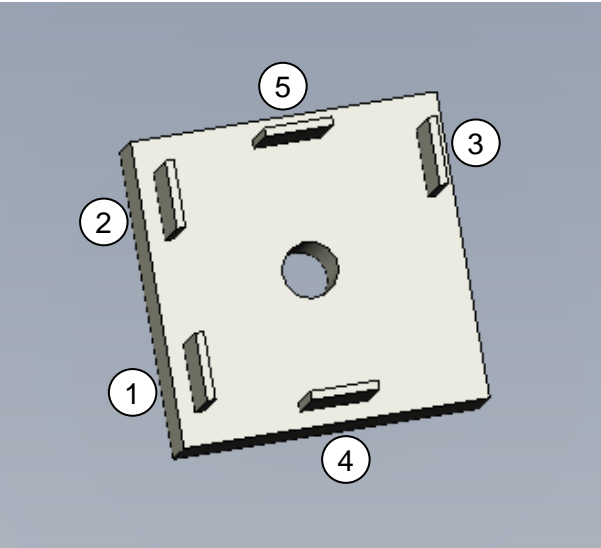

Between position 1-3 390-400VAC  
Between position 4-5 530-560VDC

IGBT (Transistor)  
A4000/A1200/A1100/A800

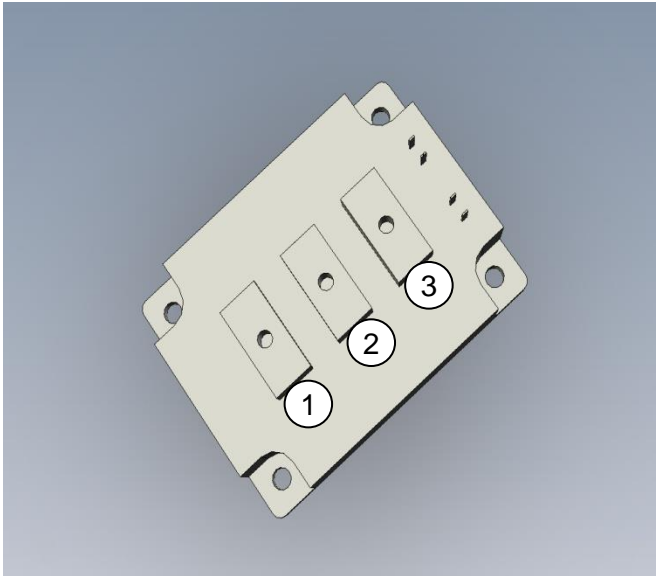

Between position 2-3 540-560VDC

## Diode test:

Rectifier SKD 62/16, SKD 26MT120

Disconnect the mains and check that there is no residue voltage left before measuring starts.

Start with the diode test beeper on, machine power off and no cables attached.

A correct rectifier should show between 0.5V to 0.8V between the diodes.

It beeps briefly for a normal junction and is on continuously if a short circuit is detected.

## IGBT (Transistor)

Disconnect the mains and check that there is no residue voltage left before measuring starts.

Start with the diode test beeper on.  
Disconnect all connections to the IGBT.

Correct IGBT should show between 0.5V to 0.8V between the diodes.

It beeps briefly for a normal junction and is on continuously if a short circuit is detected.

## How to check and measure the SST12

Disconnect the mains and check that there is no residue voltage left before measuring starts.

Open the top and locate the SST12  
Picture 1 A4000 Picture 2 A1100/A1200  
Picture 3 A800.

Look for cracks and burn spots at the SST12 Picture 1-3.

Measure the current limiters at the SST12 circuit board. The correct value is 10 Ohm  $\pm 25\%$  at 25 °C Picture 4. If correct the varistors should not lead only if broken.

If necessary change SST12 and check that the contactors aren't locked. **Please note the SST12 position and direction.**  
Picture 1- 3

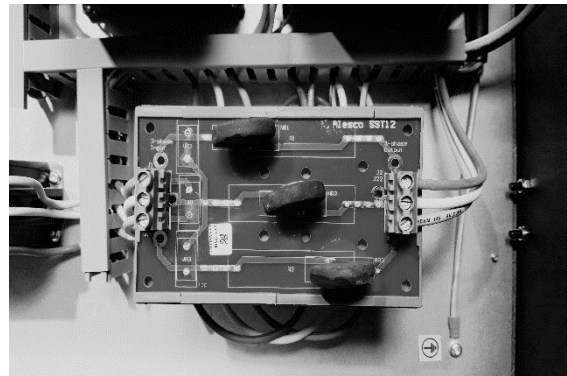

Picture 1 A4000

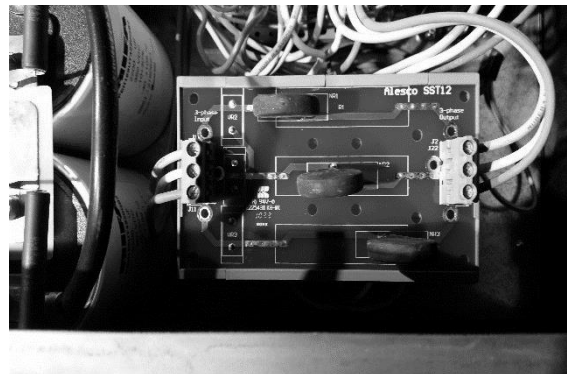

Picture 2 A1100/A1200

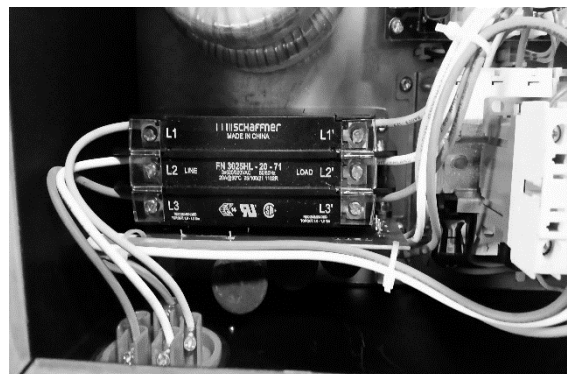

Picture 3 A800

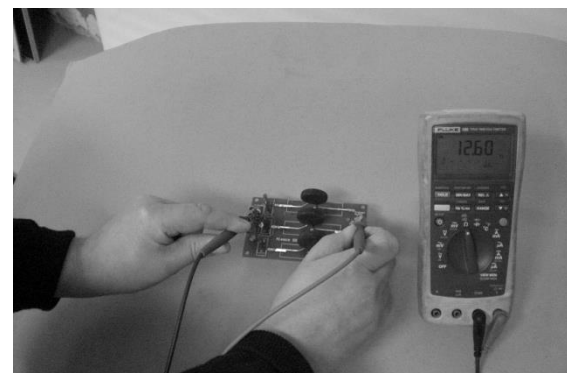

Picture 4

## Checking the P and N channels at the ICB31

Measure between the soldering points at the ICB31. The value shall be -9V at both N and P channel.

Measure between anything else than these soldering points will destroy the ICB31. Picture 2

If the measured value is  $-9V \pm 10\%$  at only one channel change the ICB31.

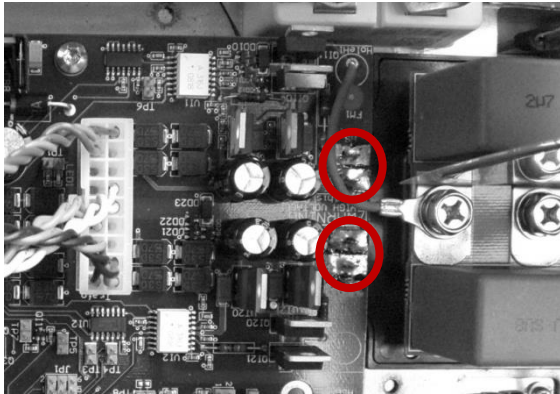

Picture 1 P and N channels.

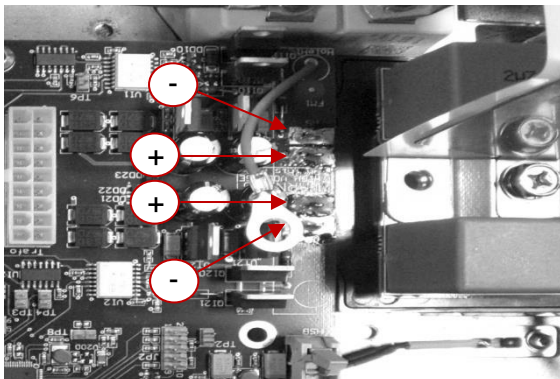

Picture 2

## Disassembly and mounting ICB31

Disassembly:

Disconnect the mains and check that there is no residue voltage left before work starts.

Open the top and locate the PE+ screw. Unscrew it. Picture 3

Open the top lid and locate the ICB31. Disconnect all plugs and the red check cable to the IGBT. Picture 4

Unscrew all mountings at the ICB31. Note! Red marking not in use. Picture 5

Remove the soldering from the four soldering points at the front side of the ICB31. Note! Oval red marking Picture 5

Remove the ICB31.

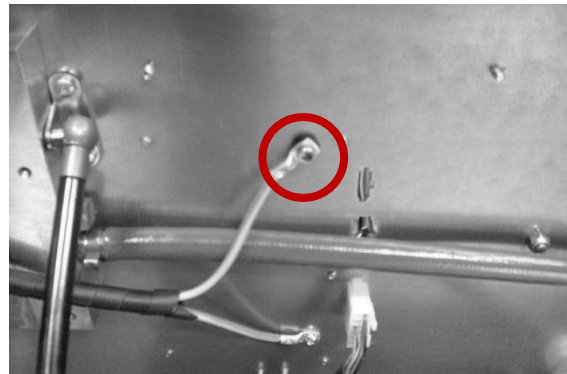

Picture 3



Picture 4

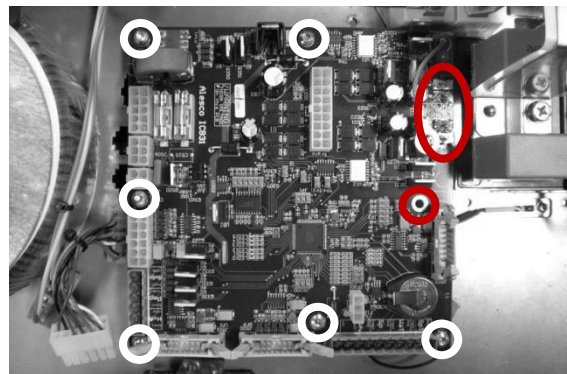

Picture 5

Mounting:

Unsolder the red check cable from the old ICB31 and use at the new ICB31. Cable marked red Picture 6

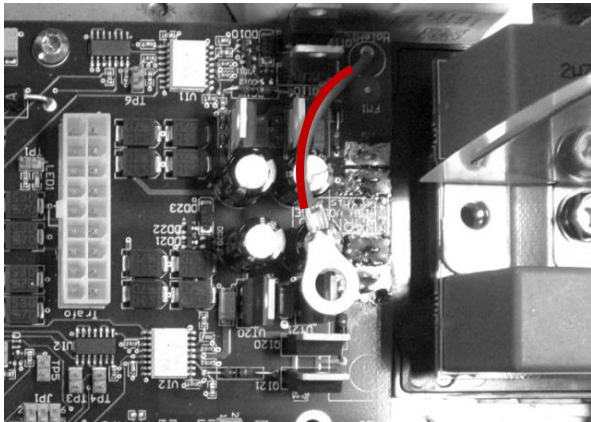

**Picture 6**

Put the new ICB31 in place use on or two mounting screws as guides before soldering.

Finish soldering and mount the rest of the screws. When all screws are in place mount the battery, all plugs and PE+ cable.

## **Disassembly and mounting CCB10**

Disassembly:

Disconnect the mains and check that there is no residue voltage left before work starts.

Open the top and secure it with the lock arm. Picture 1

Open the lid at the cooling unit electrical box with the wing nut. Locate the CCB10 Picture 2

Disconnect the all plugs connecting to the CCB10. Release the CCB10 from the DIN-rail, tilt the two locks from the DIN-rail.

Picture 3

Mount in reverse order. Mount the electrical box's lid and close and lock the machine.

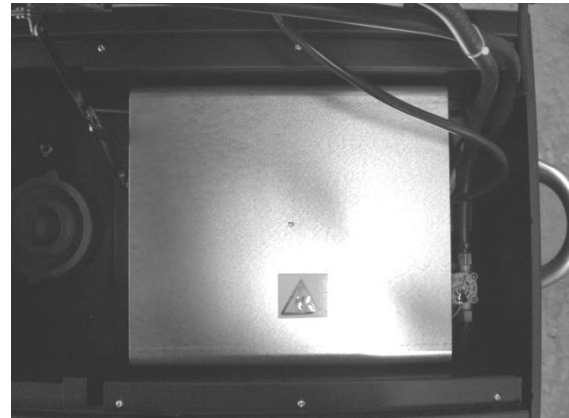

**Picture 1**

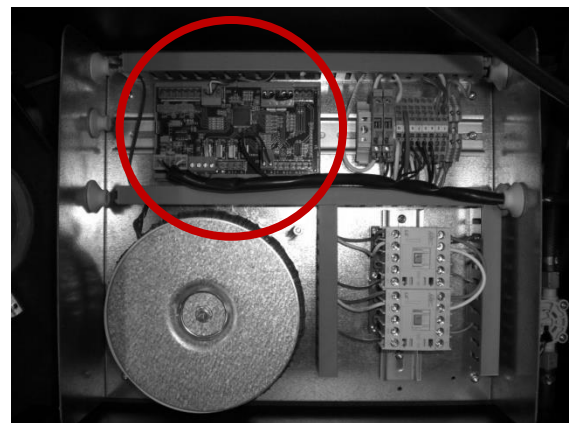

**Picture2**

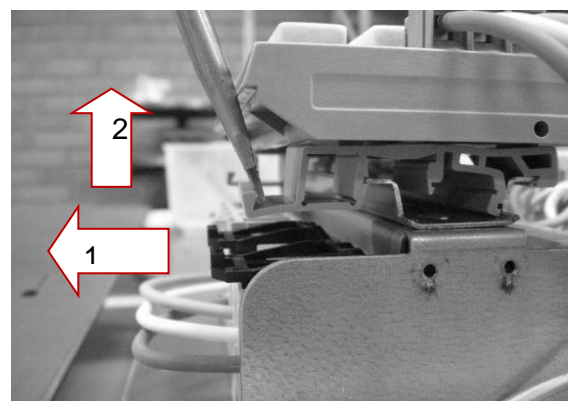

**Picture 3**

## Disassembly and assembly the GFP22 with membrane circuit board.

Disassembly:

Disconnect the mains and check that there is no residue voltage left before work starts.

Unscrew the 14 torx that secures the top lid. Picture 4

Open the top and secure it with the lock arm, unscrew the 3 remaining torx at the top lid front. A4000/A1100/A1200 only. Picture 5

Close the top lid and pull the lid up and forward to tip it in open position. Disconnect the plugs (pos 1, 2, 3) at the GFP22 and put the top lid at a workbench. Picture 5

Unscrew the mountings with a 7 mm socket wrench and lift the GFP22 straight up. Picture 3

Unscrew the front frame 4 screws, NOTE! The transparent plastic and pull the membrane off. Picture 9-11. Mount in reverse order.



Picture 4

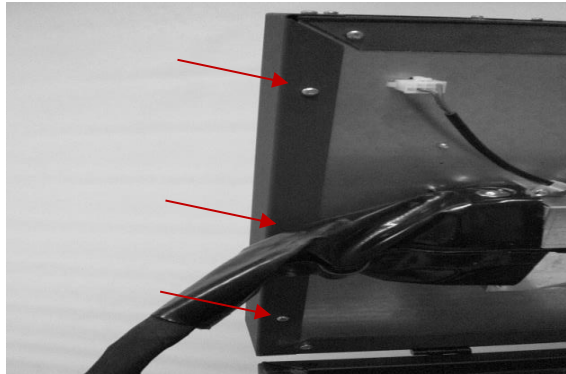

Picture 5

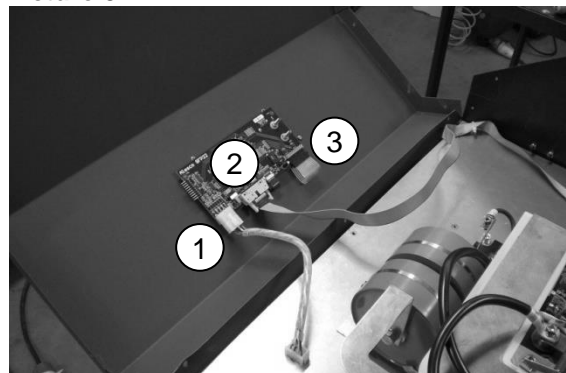

Picture 5

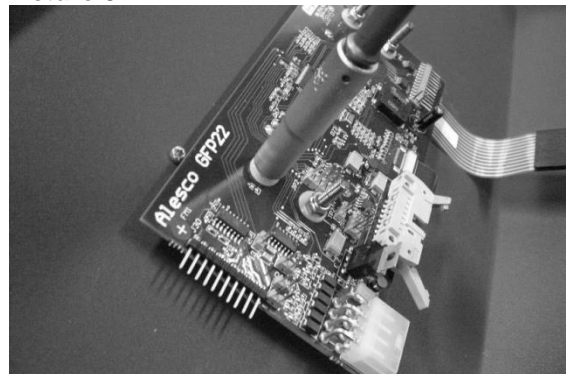

Picture 6



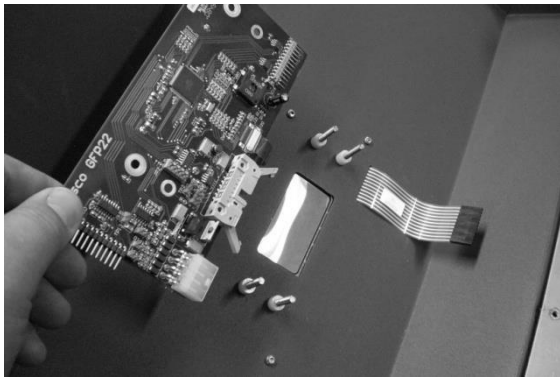

Picture 7



Picture 11

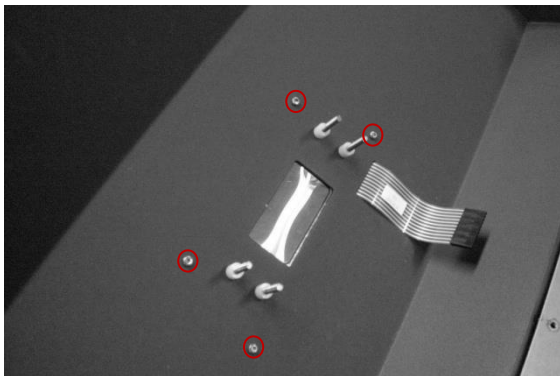

Picture 8



Picture 9



Picture 10

**Flow sensor  
A4000/A1100/A1200/A800**

Measure the flow rate:



A4000/ A1100:

Measure frequency white (Vout) and black (Gnd) at CCB10 on J25.

A800:

Measure frequency white (Vout) and black (Gnd) at ICB31 on J321.

At normal state the frequency reading is between 19-22Hz and can vary if the machine is warm or cold. The flow alarm triggers at 10Hz. Accuracy: +/- 10%

Flow sensor disassembly.



1. Flow sensor housing.
2. Impeller.
3. Lid with sensor.

**Hose package A4000/  
A1100/A1200/A800**

Isolations test:

This test is to check if the isolation at the cables inside hose and transformer don't have damages that will short circuit.

Disconnect the mains and check that there is no residue voltage left before measuring starts.

Range settings 500V-1000V. **Do not test above 1000V**

Don't tap the hose package from water. Disconnect both black cables to start testing. Connect the test probes at one of the black cables and earth cable.

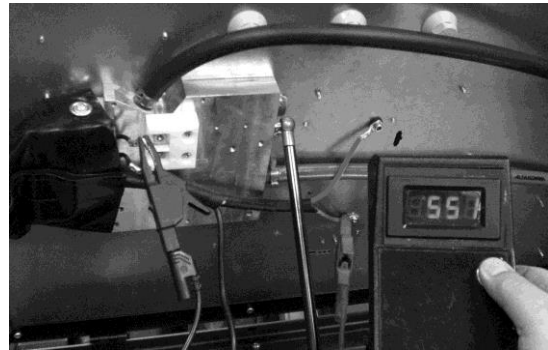

Induction test:

This test is to check if the cables inside hose and transformer have the correct numbers of rotations. This test is only preformed if the isolations test didn't give a clear answer.

Disconnect the mains and check that there is no residue voltage left before measuring starts. Calibrate the instrument.

A4000/A1100/A1200

Unscrew the inductor. Disconnect both black cables to start testing. Connect the test probes at the black cables. A correct reading value is .550 mH. If the value is more than +/-5% the hose package need to be replaced.

A800

Unscrew the inductor. Disconnect both black cables to start testing. Connect the test probes at the black cables. A correct reading value is .812 mH. If the value is more than +/-5% the hose package need to be replaced.

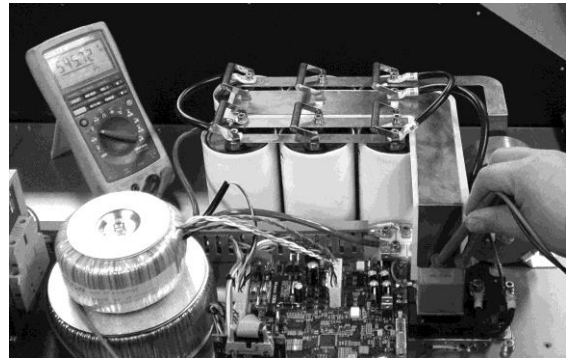
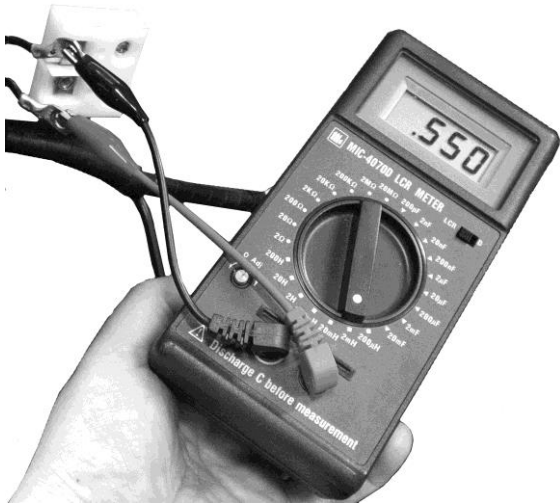
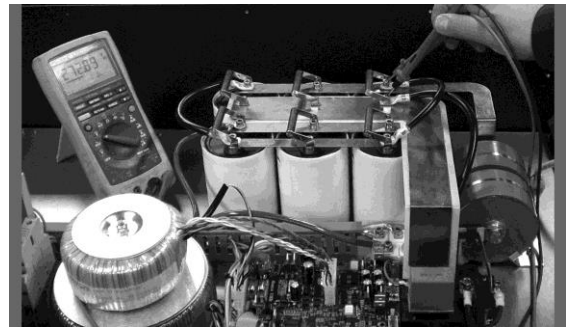

The VDC reading at the transistor is the sum of both sides.

### Capacitors bank testing A4000/A1100/A1200/A800 NOTE! High voltage area!

Measure the VDC to check that the capacitors values are equally and at the correct level. This is important because an uneven value will destroy the transistor.

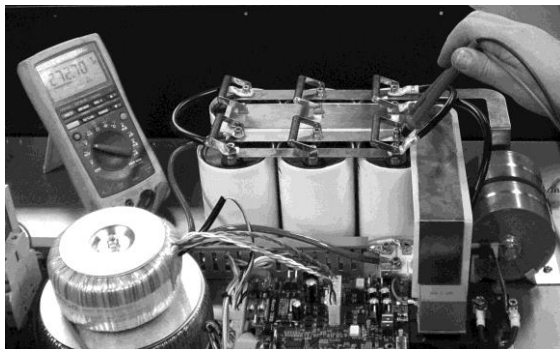

VDC values should be even at both sides at the two copper rails that divide the capacitor bank.

## Test of current level

**NOTE! High voltage area!**

A4000/A1100/A1200/A800

This test is to check if the outgoing current (hose package) is at the right level. High current levels and machine will show error code and low current levels will decrease the machines performance.

Place the power pliers around the black cable that's connected to the C2E1 at the transistor. High levels of current indicate that the inductor is worn or broken.

A4000 normal value is 90-95 Amps.

A1100 normal value is 65-70 Amps.

A1200 normal value is 65-70 Amps.

A800 normal value is 55-60 Amps.

