

The WDK certificate stands for the highest quality and safety!

The tire is no longer just a piece of rubber.

It is a high-tech product, which has to meet the highest standards and demands.

- The WDK certificate is the HIGHEST label for tire mounting machines.
- The TW X-36 WDK is a tire mounting machine, of professional class, tested with the strictest WDK guidelines.
- Your advantage: You have the option to register as a certified WDK installer and show your customers that they could not be in better hands!

The correct way makes all the difference. Incorrect installation may subsequently lead to serious accidents.

⊕ 14"-26"

⊕ 12"-24"

⚡ 400 V

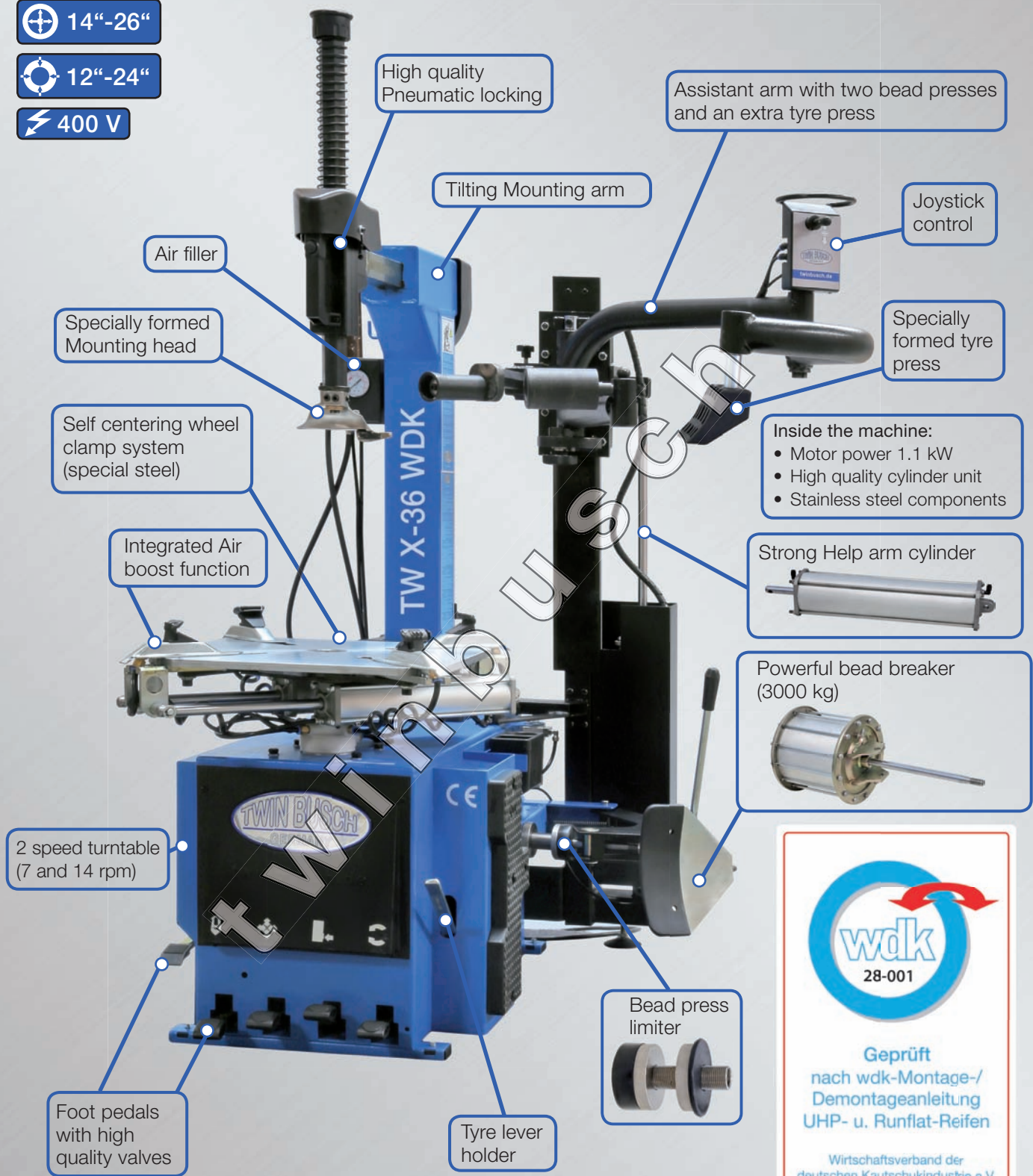

Geprüft
nach wdk-Montage-/
Demontageanleitung
UHP- u. Runflat-Reifen

Wirtschaftsverband der
deutschen Kautschukindustrie e.V.

The new TOP-Model - 2 Speed with WDK-certificate!

Description

TW X-36 WDK - 2 Speed with WDK-certificate!

Tyre changer with pneumatic tilting mounting arm and a built-in air booster.
 For standard, low profile, UHP and run-flat tires. Including assistant arm.
 The TW X-36 WDK is a tire mounting machine of a professional class, tested with the strictest WDK guidelines.
 The TW X-36 is characterized by many additional features, such as the assistant arm with two tyre rollers, specially shaped presses, a dismantling disc, an extra thick bead breaker, (adjustable) 2-speed rotary table (7 and 14 rpm), adjustable bead holder, bead chain, Rim flange protection and a certified WDK installation tyre lever. With the TW X-36 WDK is a professional and damage free removal and installation is guaranteed.

Features

- WDK certificate | Quality workmanship
- Manufactured in accordance to ISO 9001
- 2 speed turntable (7 and 14 rpm)
- Adjustable tilting arm
- Robust construction
- Tyre and rim damage free mounting according to WDK
- Pneumatic mounting head locking
- Strong bead breaking (3000 kg)
- Large clamping range 12" - 26"
- Built in Air booster to aid tyre fitting
- Changeable mounting head rim protectors
- Strong electric motor for easy tyre fitting
- High quality steel clamps for long life
- Quality controls for fine adjustment and stop function
- Stainless steel internal parts (advantage: no rust)
- Self centring 4 clamping system

Delivery contents

- Tyre changer with maintenance unit
- Air filler and tyre lever according to WDK
- Rim protector
- Bead press (adjustable)
- Bead chain
- Bead press restrictor
- Plastic protectors for the mounting jaws (4 pcs.)
- Plastic protectors for the mounting head (set 3 pcs.)
- Operating instructions

Details



- (1) Extremely convenient mounting through two rollers on the assistant arm, specially shaped mounting press disc.
- (2) Bead chain holder according to WDK.
- (3) Powerful assistant arm
- (4) Less damage to tyres and rims due to the two roller presses
- (5) Two way speed switch
- (6) Pneumatic mounting head locking

Dimensions | Technical data | Accessories

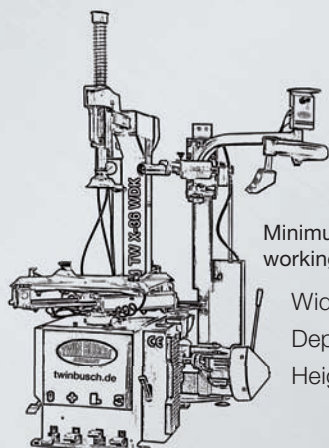

Minimum required working space:
 Width: 1500 mm
 Depth: 1650 mm
 Height: 1800 mm



Extensive accessories

Technical Data: TW X-36 WDK	
Clamping range outside	12" - 24"
Clamping range inside	14" - 26"
Wheel diameter (max.)	45" (1143 mm)
Wheel width (max.)	16" (406 mm)
Bead breaker force	3000 kg
Air supply	8-10 bar
Power supply	400 V / 3 Phase
Motor power	1,1 kW
Revolution speed	7 and 14 U/min.
Noise level	<70 dB
Weight (approx.)	360 kg